

ChargerPro™  Series

 Shire - 1" Series

Air Draw Filtration Systems

Iron Breaker™

Installation Instructions and Owners Manual

Congratulations on the purchase of your new water filter featuring the Shire control system. Enjoy lasting peace of mind, knowing your system is built to deliver years of reliable, filtered water.



CHARGER
Water Treatment Products



*Delivering Cleaner, Healthier
Water Across America*

www.chargerwater.com

Table of Contents

Installation Information: Your Water Test1
 Pre-Installation Instructions2
 Installation.....3-4
 Bypass Valve Operation5
 Start Up Instructions6
 Front Cover and Drive Assembly.....7
 Valve Body Piston Seal Parts Diagram8
 Injector Parts9
 Installer Display Settings.....10
 User Display Settings.....11-12
 General System Information.....13
 Spec Sheet14
 Product Warranty.....15

ORIGINAL INSTALLATION INFORMATION

Water Treatment Professional: _____ Phone: _____
 Installation Date: ____/____/____
 Install location: _____
 Model No: _____
 Serial No: _____
 Water Test: Hardness ____ TDS ____ pH ____ Iron ____ Manganese ____ Sulfur ____
 Water Source: City Well Other
 Unit Capacity: Max ____ Min ____ Per Regeneration
 Mineral Tank Size: Diameter ____ Height ____
 Time of Regeneration: ____ AM PM
 DLFC: ____ GPM
 Injector#/Color: _____

Your Shire Air Draw Filtration System is a precision built, high quality product. This unit will deliver filtered water, for many years, when installed and operated properly. Please study this manual carefully. This manual should be kept for future reference.

If you have questions regarding your air draw filter, contact your local Water Treatment Professional or Charger Water Treatment Products at 8150 N. Lehigh Ave, Morton Grove, IL 60053 • www.chargerwater.com

Pre-Installation Instructions

The manufacturer has preset the water treatment unit's cycle times for backwash, rinse, and air draw.

The water treatment professional should read this page and guide the installer through setting the Days Override and Time of Regeneration prior to installation.

For the installer, the following settings should be used:

1. **Program Installer Settings**
 - A. -Gallon Capacity (if metered)
 - B. -Day Override (factory set to 3)
 - C. -Time of Regeneration (preset to 12:00AM)
2. **Set Time of Day**
 - A. -For the homeowner, please read user display settings.

Water Air Draw Filtration System:

During operation, the normal user display is time of day or volume remaining. Other displays are available and can be viewed by pressing NEXT to scroll through them. When stepping through any programming, if nothing is pressed within 5 minutes, the display returns to a normal user display. Any changes made prior to the 5-minute time out are incorporated.

To quickly exit any programming, installer settings, etc., press CLOCK. Any changes made prior to the exit are incorporated. If desired, two regenerations within 24 hours are possible with a return to the preset program. To do a double regeneration:

1. Press REGEN once. "REGEN TODAY" will flash on the display.
2. Press and hold REGEN for three seconds until the regeneration begins.

Once the control valve has completed the immediate regeneration, it will do another one at the next scheduled regeneration time.

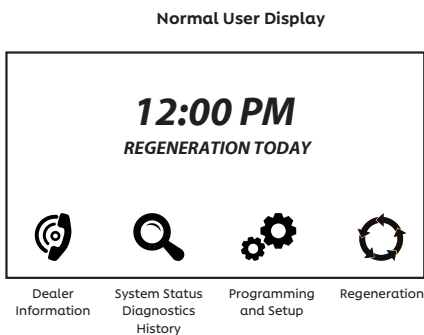

DISPLAY NAVIGATION

Pressing HOME from any screen will return control to the normal display. Pressing and holding Home for >3 seconds activates LCD test, software version display, rehomes the valve and all active MAVs, and resets manual regeneration requests.

MASTER RESET

To reset the control, go to Set Up Screen #3. Press and hold the area NEXT TO the text "Set Up Screen #3" until the display blanks. This rehomes the valve and any active MAVs, resets a manual regeneration request, and resets Programming and Diagnostics displays to factory defaults. Valve History is retained.

RETURN/ENTER

Pressing the Enter button will save any values that have been changed using UP or DOWN.

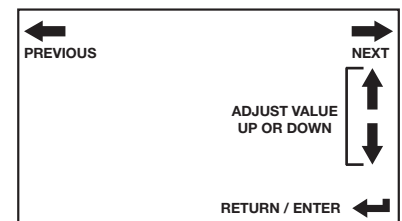
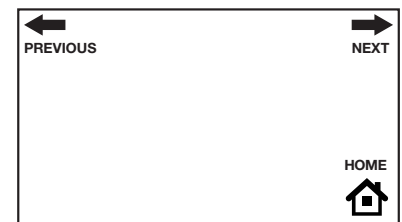

Installation

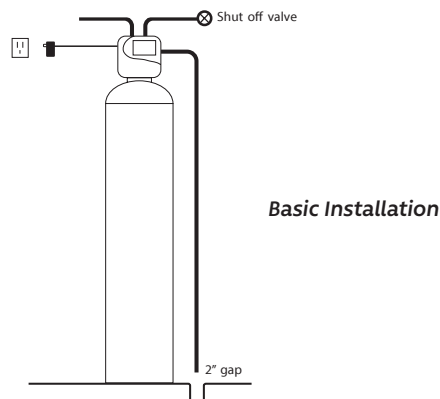
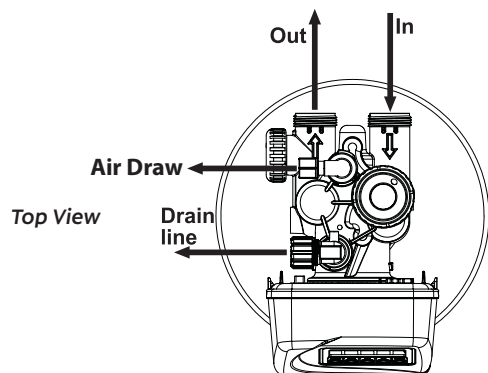

GENERAL INSTALLATION & SERVICE WARNINGS

The control valve, fittings, and/or bypass are designed to accommodate minor plumbing misalignments but are not designed to support the weight of a system or the plumbing.

Do not use Vaseline, oils, other hydrocarbon lubricants or spray silicone anywhere. A silicone lubricant may be used on black o-rings, but is not necessary.

Do not use pipe dope or other sealants on threads. Teflon tape must be used on the threads of the 3/4" NPT connection and on the threads for the drain line connection. Teflon tape is not necessary on the nut connections or caps because o-ring seals are used. The nuts and caps are designed to be unscrewed or tightened by hand or with the special plastic service wrench, V3193-02. If necessary, a pliers can be used to unscrew the nut or cap. Do not use a pipe wrench to tighten or loosen nuts or caps. Do not place screwdriver in slots on caps and/or tap with a hammer.

SITE REQUIREMENTS:

- Water pressure, 40-90 psi
- Water temperature, 40°-100°F
- The tanks should be on a firm, level surface
- Current draw is 0.25 amperes
- A 15-foot power cord is furnished
- The plug-in transformer is for dry locations only
- Electrical: Use a 115/120v, 60Hz uninterrupted outlet

1. The distance between the drain and the water filter should be as short as possible. All plumbing should be done in accordance with local plumbing codes.
2. Do not install any water filter, with less than 10 feet of piping, between its outlet and the inlet of a water heater. Protect system from vacuum, reverse flow, and negative pressure.
3. Do not locate unit where it or its connections (including the drain and overflow lines) will ever be subjected to room temperatures under 34°F.
4. **INLET/OUTLET PLUMBING:** Connect to a supply line downstream of outdoor spigots. Install an inlet shutoff valve and plumb to the unit's bypass valve inlet located at the right rear as you face the unit. There are a variety of installation fittings available. They are listed under Installation Fitting Assemblies. When assembling the installation fitting package (inlet and outlet), connect the fitting to the plumbing system first and then attach the nut, split ring, and o-ring. Heat from soldering or solvent cements may damage the nut, split ring, or o-ring. Solder joints should be cool and solvent cements should be set before installing the nut, split ring, and o-ring. Avoid getting solder flux, primer, and solvent cement on any part of the o-rings, split rings, bypass valve, or control valve. If the building's electrical system is grounded to the plumbing, install a copper grounding strap from the inlet to the outlet pipe. Plumbing must be done in accordance with all applicable local codes.

7. **DRAIN LINE:** First, be sure that the drain can handle the backwash rate of the system. Solder joints near the drain must be done prior to connecting the drain line flow control fitting. Leave at least 6" between the drain line flow control fitting and solder joints. Failure to do this could cause interior damage to the flow control. Install a 1/2" I.D. flexible plastic tube to the drain line barb assembly or the 5/8" O.D. nut assembly and use the 3/4" NPT fitting for rigid pipe. Where the drain line is elevated but empties into a drain below the level of the control valve, form a 7" loop at the discharge end of the line so that the bottom of the loop is level with the drain connection on the control valve. This will provide an adequate anti-siphon trap. Where the drain empties into an overhead sewer line, a sink-type trap must be used. Run drain tube to its discharge point in accordance with plumbing codes. Pay special attention to codes for air gaps and anti-siphon devices.

IMPORTANT: Never insert a drain line directly into a drain, sewer line, or trap. Always allow an air gap between the drain line and the wastewater to prevent the possibility of sewage being back-siphoned into the conditioner.

8. **SERIAL NUMBER:** Record the serial number on the installer's and customer's records.
- Bypass Valve - The bypass valve is typically used to isolate the control valve from the plumbing system's water pressure in order to perform control valve repairs or maintenance.

Bypass Valve

The bypass valve is particularly unique in the water treatment industry due to its versatility and state-of-the-art design features. The 1" full flow bypass valve incorporates four positions including a diagnostic position that allows service personnel to work on a pressurized system while still providing untreated bypass water to the facility or residence. Its completely non-metallic, all plastic design allows for easy access and serviceability without the need for tools.

The bypass body and rotors are fiber reinforced composite and the nuts and caps are glass-filled polypropylene. All seals are self-lubricating EPDM to help prevent valve seizing after long periods of non-use.

The bypass consists of two interchangeable plug valves that are operated independently by red, arrow-shaped handles. The handles identify the flow direction of the water. The plug valves enable the bypass valve to operate in four positions. (See page 5)

1. **Normal Operation Position:** The inlet and outlet handles point in the direction of flow indicated by the engraved arrows on the control valve. Water flows through the control valve during normal operation and this position also allows the control valve to isolate the media bed during the regeneration cycle. (See Figure 1 on page 5)
2. **Bypass Position:** When the inlet and outlet handles point to the center of the bypass, the control valve is isolated from the water pressure contained in the plumbing system. Untreated water is supplied to the plumbing system. (See Figure 2 on page 5)
3. **Diagnostic Position:** The inlet handle points in the direction of flow and the outlet handle points to the center of bypass valve, system water pressure is allowed to the control valve and the plumbing system while not allowing water to exit from the control valve to the plumbing. (See Figure 3 on page 5)
4. **Shut Off Position:** When the inlet handle points to the center of the bypass valve and the outlet handle points in the direction of flow, the water is shut off to the plumbing system. If water is available on the outlet side of the softener, it is an indication of water bypass around the system (i.e. a plumbing connection somewhere in the building bypasses the system). (See Figure 4 on page 5)

Bypass Valve Operation

NORMAL OPERATION

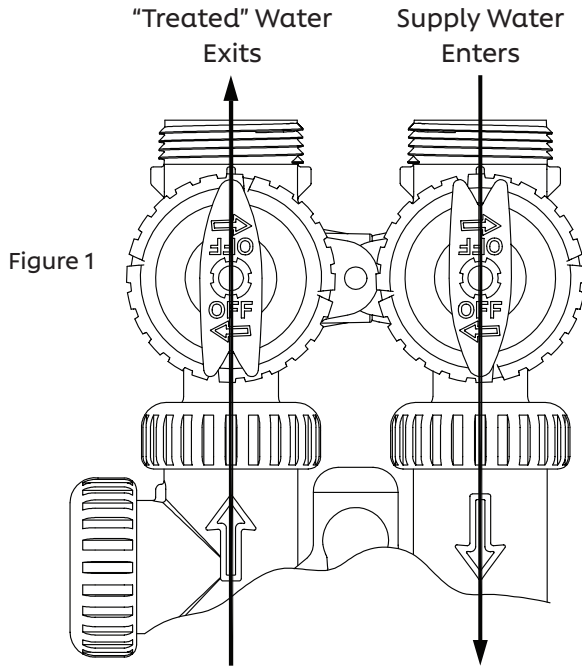

BYPASS OPERATION

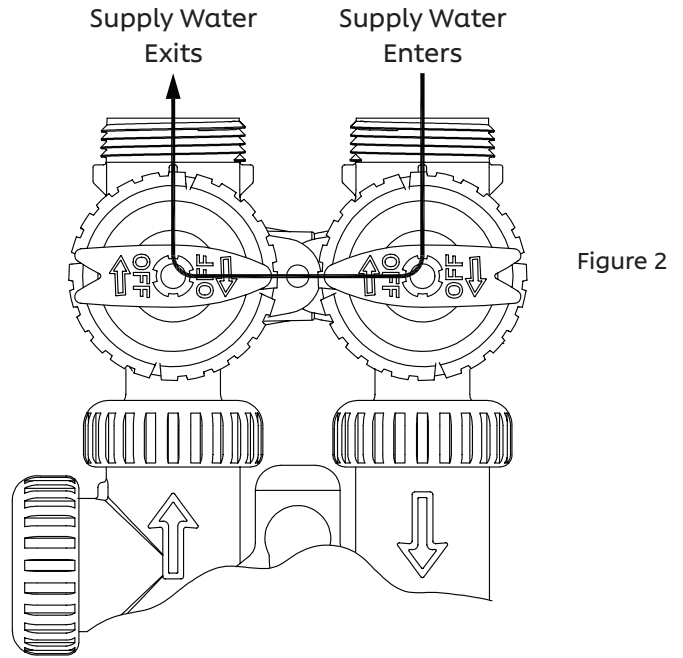

DIAGNOSTIC MODE

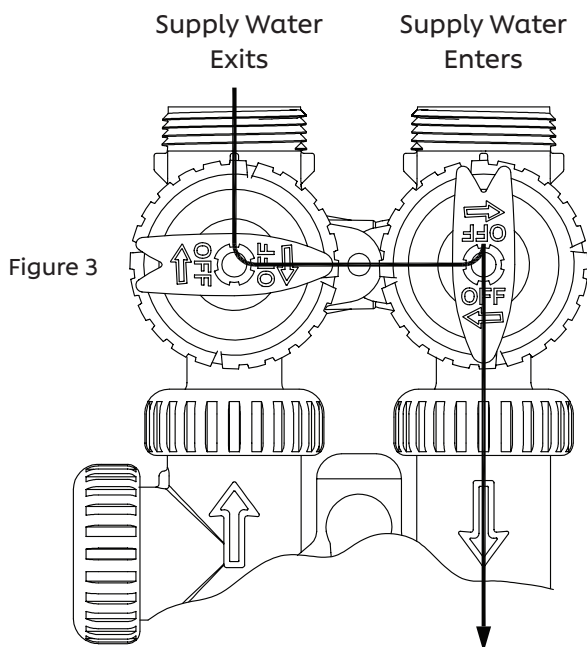

SHUT OFF MODE

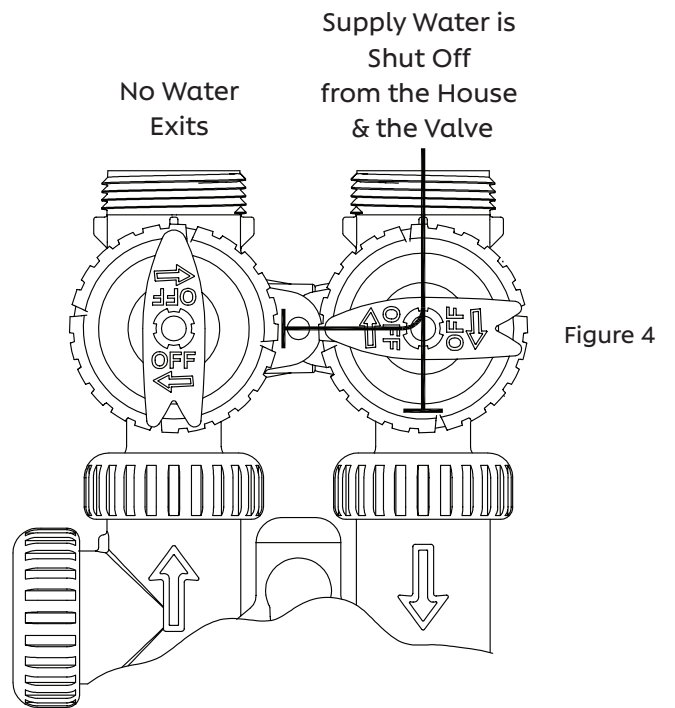

Start Up Instructions

- A. After installation is completed and checked for leaks, rotate the bypass handles to the bypass position. (See Bypass Valve Diagram on page 5.)
- B. Fully open a cold water faucet.
- C. Allow water to run until clear to rid pipes of debris, which may have occurred during installation.
- D. The system is now ready for testing:
 - 1. Press and hold REGEN for about three seconds until the drive motor starts. Wait until the motor stops and the display reads "BACKWASH." The backwash time will begin to count down.
 - 2. Open the inlet handle of the bypass valve, very slightly, allowing water to fill the tank slowly in order to expel air. CAUTION: If water flows too rapidly, there will be a loss of media out of the drain.
 - 3. When the water is flowing steadily to the drain without the presence of air, press REGEN to advance the control to the air draw position. The air draw time will begin to count down.
- E. Fully open the inlet bypass valve handle (bypass is now in the Diagnostic Position - see page 5 for illustration). Check to verify that air is being drawn. There should be a slow flow to the drain. Allow three minutes for the media bed to settle.
- F. Press REGEN again to advance the control to the next position and allow water to run to drain for 2-3 minutes. Control will transfer and the display will read "BACKWASH" or "RINSE" depending on the program used. If "BACKWASH" is displayed, press REGEN to advance the control to the RINSE position. Allow water to run to drain until clear.

Front Cover and Drive Assembly

Drawing No.	Order No.	Description	Quantity
1	V4374-01	CU FRONT TOUCHSCREEN CVR ASSY	1
2	V3107-01	CU MOTOR	1
3	V3002-A	CU DRIVE BRACKET ASY	1
4	V4371CU-BOARD	CU THRU 2 CU PCB REPLACE	1
5	V3110	CU DRIVE REDUCING GEAR W/DECAL	3
6	V3109	CU DRIVE GEAR COVER	1
Not Shown	V3186-06	CU POWER SUPPLY US 15VDC HOCP	1
Not Shown	V3946	CU DRIVE BACK PLATE	1

Refer to Control Valve Service Manual for other drawings and part numbers.

Relay Driver Output Type – Single Solid-State 12VDC “wet” contact - N.O. Relay
 Driver Output Capacity - 12VDC @100mA

NOTE: Check for proper mounting dimensions on valve back plate prior to mounting an external relay under control cover.

Power Supply	U.S.
Supply Voltage	100-120 VAC
Supply Frequency	50/60 Hz
Output Voltage	15 VDC
Output Current	500 mA

Wiring for Correct On/Off Operation	
PC Board Relay Terminal Block	Relay
RLY1	Coil -
+COM	Coil+
RLY2	Coil-

When replacing the battery, align positives and push down to fully seat.

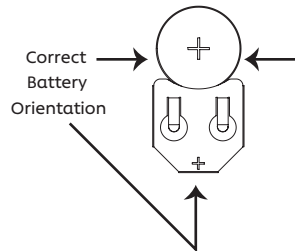
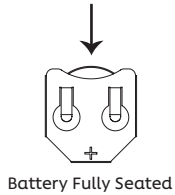

Battery replacement is 3 volt Lithium coin cell type 2032.

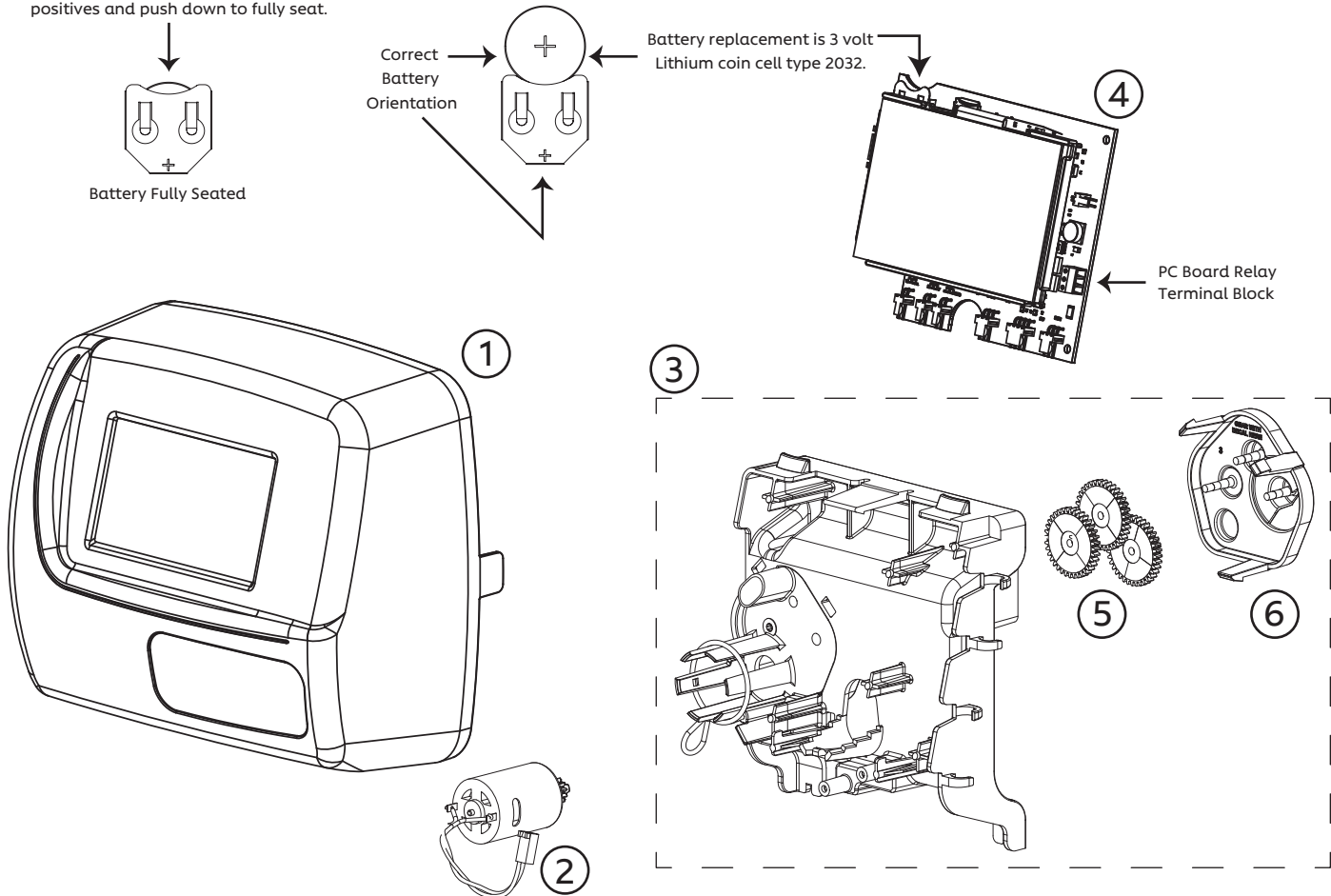

Valve Body Piston Seal Parts Diagram

Drawing No.	Order No.	Description	Quantity
1	V3005-02	CU SPACER STACK ASSEMBLY	1
2	V3004	DRIVE CAP ASSEMBLY	1
3	V3946	CU WIDE DRIVE BACK PLATE	1
4	V3011*	CU PISTON DOWNFLOW ASSEMBLY	1
5	V3174	CU REGENERANT PISTON	1
6	V3135	O-RING 228	1
7	V3180	O-RING 337	1
8	V3105	O-RING 215 (DISTRIBUTOR TUBE)	1
Not Shown	V3001	CU BODY ASSEMBLY DOWNFLOW	1
	BUGSCREEN	BUG SCREEN	1
	OV15HT	NEO CHECK	1
	NEOWASH	NEO WASHER	1
	V3957	INTERNAL CHECK VALVE	1

*V3011 is labeled with DN.

Note: The regenerant piston is not used in backwash only applications.

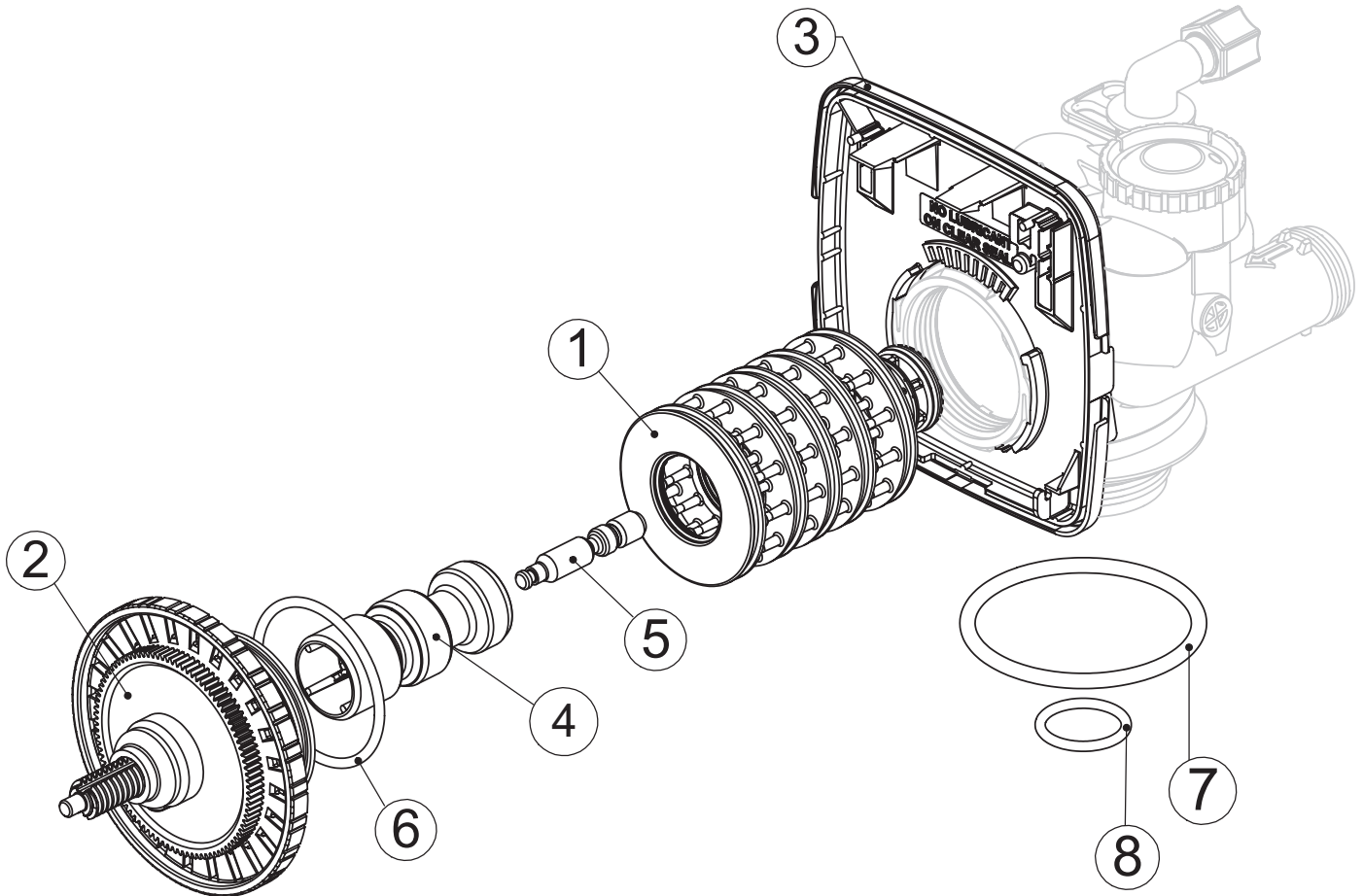

Injector Cap, Injector Screen, Injector, Plug, and O-Ring

Drawing No.	Order No.	Description	Quantity
1	V3176	INJECTOR CAP	1
2	V3152	O-RING 135	1
3	V3177-01	INJECTOR SCREEN CAGE	1
4	V3010-1Z	INJECTOR ASSY Z PLUG	1
5	V30101-K	INJECTOR ASSY K - LIGHT GREEN (RECOMMENDED FOR ALL AIR FILTERS)	1
Not Shown	V3170	O-RING 011	*
Not Shown	V3171	O-RING 013	*

The injector plug and the injector each contain one 011 (lower) and one 013 (upper) o-ring.

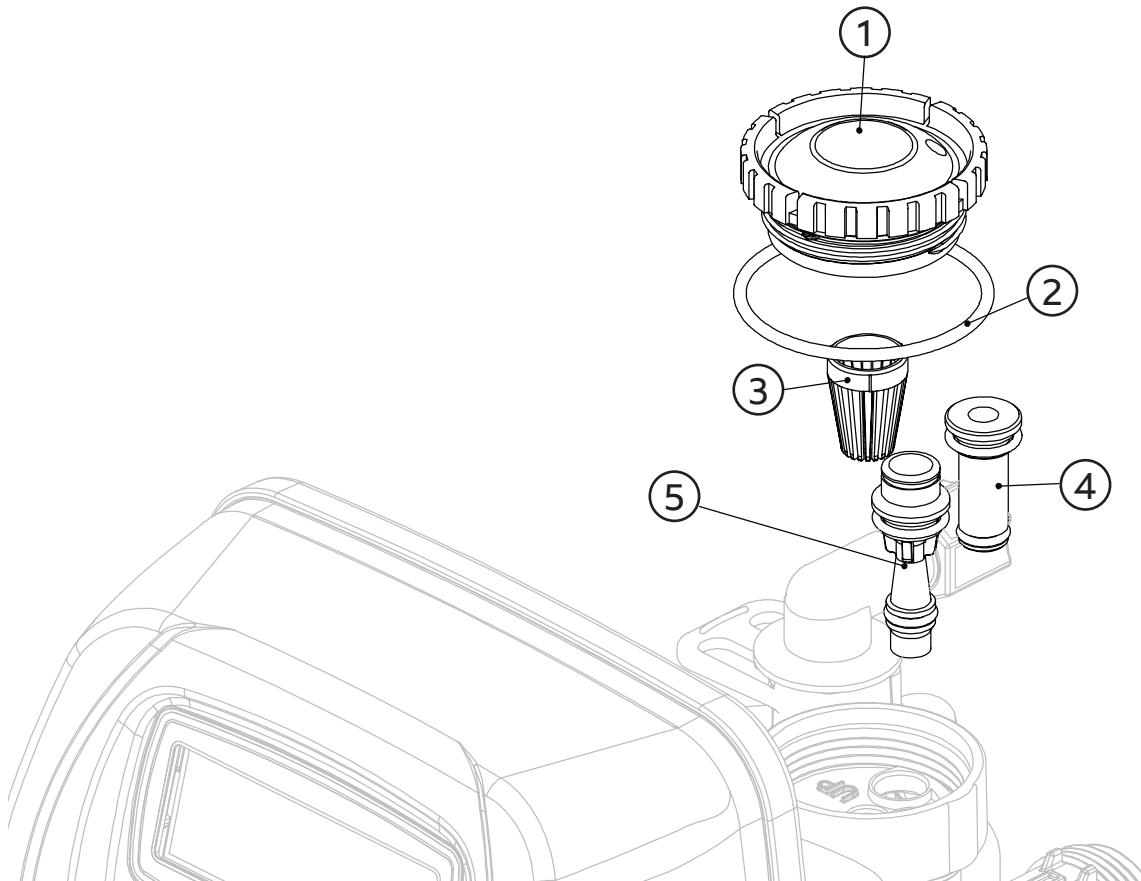

Set Time of Day



PRESS AND HOLD the Time of Day area on the Normal Display screen UNTIL the SET TIME OF DAY SCREEN appears.

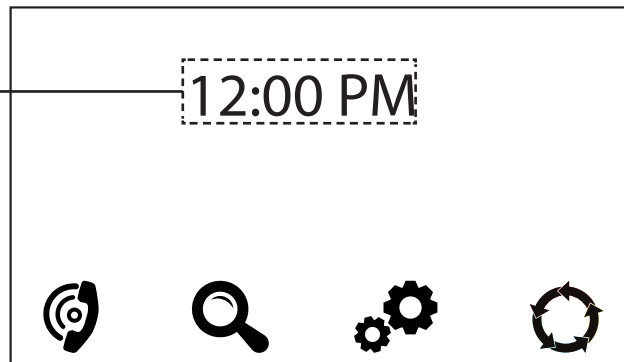

Use UP or DOWN to change the hour. AM/PM will toggle at 12:00.

NOTE: Pressing and holding the arrow will rapidly change the value

After setting the minutes, press ENTER to return to set the minutes.



Use UP or DOWN to change the minutes.

NOTE: Pressing and holding the arrow will rapidly change the value.

After setting the minutes, press ENTER to return to the Normal Display.

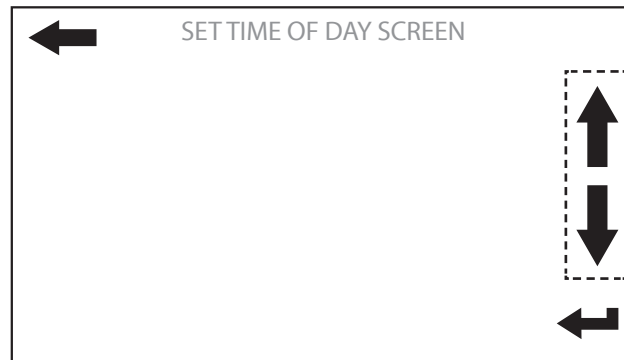

Regeneration

Press and release the regeneration button to initiate a delayed regeneration.

REGENERATION TODAY will be displayed when a regeneration will occur in the next 24 hours.

Pressing again will cancel the request.



Pressing and holding the regeneration button will force an immediate regeneration. This request cannot be cancelled.

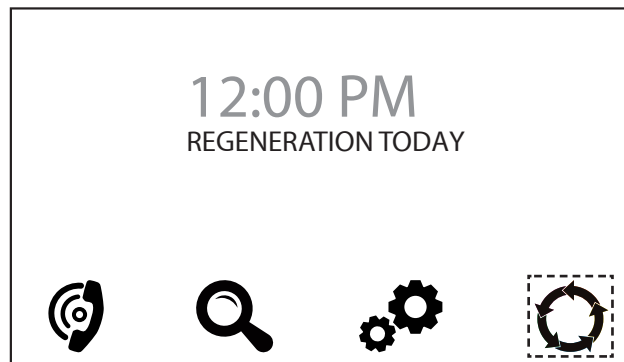

Delayed Regeneration

User Displays

REGEN PENDING will be displayed in Alternator Systems whenever a unit is waiting to initiate the first cycle step of regeneration.

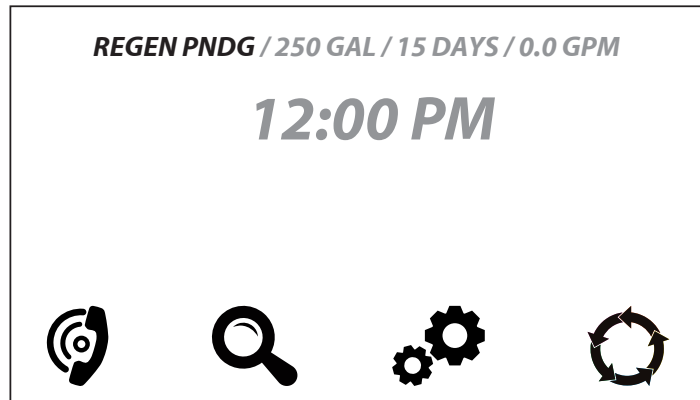

IN STANDBY will be displayed in Alternator Systems when a valve is in Standby state.

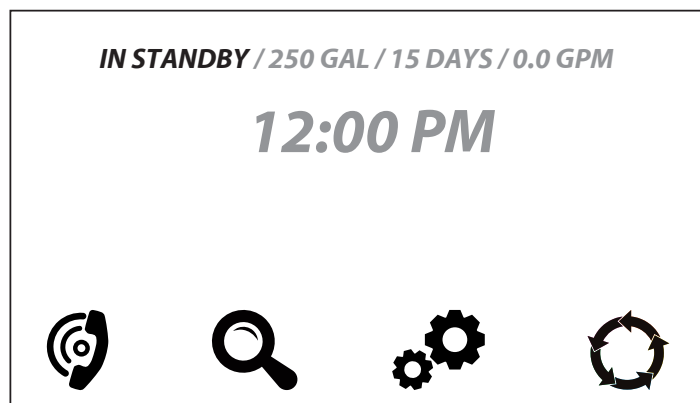

Valve Error Screen: The error screen activates as the primary screen when an error has been detected.

To reset the valve and clear the error, press and hold the area around "VALVE ERROR DETECTED" until the Normal User Display appears.

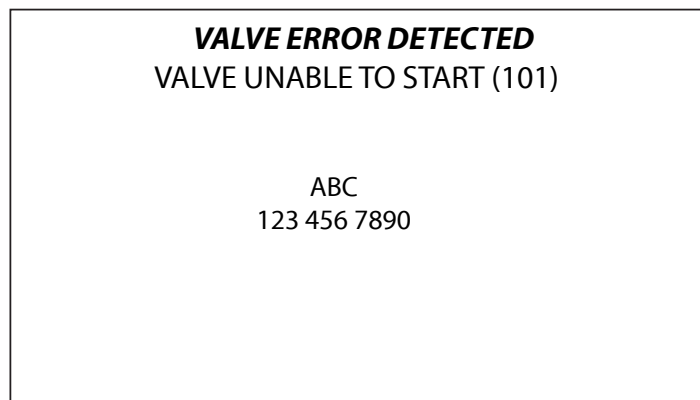

The **SCHEDULED SERVICE REQUIRED** screen appears when the set point has been reached.

The dealer information only appears if it has been set in the Dealer Information screens.

To reset the Service Alarm, press and hold the area around "SCHEDULED SERVICE REQUIRED" until the screen returns to the NORMAL DISPLAY.

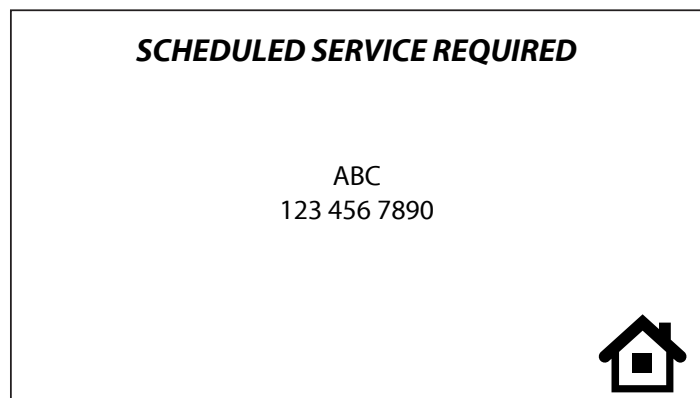

General System Information

Error Codes

Error codes are rare. The most common cause is power supply (brown out, etc.). If any error message appears, contact your Water Treatment Professional immediately.

Leaks

If there is a leak on or by your air draw, put the unit in BYPASS (see bypassing information on page 4) and contact your local Water Treatment Professional immediately.

The above issues and other concerns not listed in this manual should be addressed with your local Water Treatment Professional.

Upgrade to the Best Iron Filtration System on the Market with Safe, Dependable Ozone

EASY TO INSTALL MAINTAIN & SERVICE

In a few simple steps, the EOG 200 kit is designed to mount directly onto the ChargerPro Series control valve and includes the patented stainless steel corona discharge cell. With no chemicals or pumps to maintain, EOG is a cost effective method that provides more robust iron filtration.

PROVEN TECHNOLOGY SOLD GLOBALLY

Featuring a patented process and thousands of systems operating in the field with proven results in markets across the United States. A CE certified model is also available and sold globally.

NO HARMFUL CHEMICALS

Ozone has been proven to reduce bacteria faster than chlorine, virtually eliminating the need for traditional chemicals used to disinfect water. The EOG 200 kit is safe for non-chlorinated water sources.



Enhanced Oxygen Generator One Plug Kit*

- Ozone Output: 220 mg/hr
- One Plug Design
- Tank Size: 10", 12", & 13"
- Part Number: 31515



Enhanced Oxygen Generator Two Plug Kit*

- Ozone Output: 220 mg/hr
- Two Plug Design
- Tank Size: 10", 12", & 13"
- Part Number: 31506

Ozotech Enhanced Oxygen Generator (EOG) technology is designed to work exclusively with Charger's Thoroughbred control valves with relay drivers. By adding the EOG 200 Enhanced Oxygen Generator One Plug Kit to an air

draw filtration system, your team will quickly see the positive impact of ozone including cleaner tanks and valves, more effective filtration, increased customer satisfaction, and longer service cycles.

The EOG 200 kit reduces the nuisance bacteria within the filter and enhances iron filtration without the use of chemicals.

Water entering the iron filtration tank passes through an ozone layer where impurities are oxidized, deodorized, and enlarged so that the filter can remove them and hold them until a backwash cycle is initiated. During the regeneration process, impurities are sent to drain and a fresh ozone layer is created.

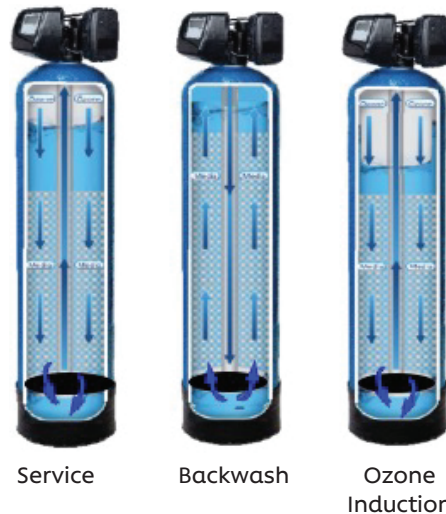

ChargerProEOG 2000 Benefits

- Cleaner tanks, more effective filtration, longer service cycles
- 3,000 times faster at oxidizing iron than chlorine
- Naturally reverts to oxygen in minutes, leaving no chemical residue
- Safe and effective when properly applied in water systems
- Does not affect the warranty of the valve
- Easy to install, maintain, and service

Typical Pre-Treatment Water Analysis

Iron	<5 ppm
Manganese	<1 ppm
pH	>6.5
IRB's:	Pink Algae, Bio film

Filtering Model	Model #	Cubic Ft Media	Mineral Tank	SVC (Service) Flow Rate	Backwash Rate
Air Draw Touchscreen Valve 	1" Standard Distributor				
	CUADF-1054-1	1 cu ft	10 x 54	5 gpm	6.5 gpm
	CUADF-1252-1	1.5 cu ft	12 x 52	7 gpm	7.5 gpm
	CUADF-1354-1	2 cu ft	13 x 54	7 gpm	9 gpm



Optional Moisture Reduction System (Air Dryer)

HOW IT WORKS: The air that is drawn into the EOG 200 unit first will pass through the moisture reduction filter. Drier air means longer service intervals in damp, humid locations such as basements, crawl spaces and well houses.

This system is not intended for outdoor use or exposure to direct sunlight.

Optional Ozone Sanitizer

The EOG 200, when combined with the ChargerPro Shire control valve, will provide active ozone during the backwash process and leaves a head of ozone in the filter. This patented process aides in the oxidization, cleaning, and the filtering of iron, manganese, sulphate and various other heavy metals from your water. This product can also aid in anti-microbial protection against nuisance bacteria and reduce unwanted odors.

ChargerPro Shire Valve Benefits

- Ability to add Dealer logo on screen
- Allows for downflow
- Up to two relay options
- Battery time back up (keeps clock accurate in power outage)
- Learn one set of programming: one board is used for 1", 1.25", 1.5"

ChargerPro Shire - 1" Series Valve Specifications

Inlet/Outlet (1).....3/4" to 1.5" NPS Adapter
 Cycles.....up to 5
 Valve Material.....Fiber Reinforced Composite
 Regeneration.....Downflow

Operating Pressures

Minimum/Maximum20 psi - 125 psi

Operating Temperatures

Minimum/Maximum40° - 110°F

Limited Warranty

Charger Water hereby warrants, to the original purchaser of its water treatment equipment*, that the control valve is free of defects in materials or workmanship for a period of 60 months for "Clack" controls. Owner shall promptly report to the Installing Retail Company or Charger Water Treatment Products, 8150 N. Lehigh Ave, Morton Grove, IL, any defect in material or workmanship and Charger Water shall, at Charger Water's option, repair or replace the part or parts involved if returned to Charger Water with transportation or freight charges prepaid. No factory labor will be charged for repairing or replacing defective parts during the limited warranty. This warranty shall not apply to any part that has been damaged by improper installation or maintenance, any modification from original design or manufacture, subjected to temperatures below 32°F, above 120°F, operated in water pressure that exceed 120 psi, any water line vacuum, or damaged by any circumstance beyond our control.

Subject to all conditions and limitations set above, at the site of original installation; any residential mineral tank proved defective in material or workmanship will be warranted for a period of 10 years.

**All other and/or fittings, mineral tank internal components shall be warranted to be free of defects in material and workmanship for a period of one year subject to conditions and limitations set forth above.*

This warranty sets forth Charger Water's sole obligation and purchaser's exclusive remedy for defective product. Charger Water shall not be liable for consequential, incidental, or contingent damages whatsoever.

The forgoing warranties are exclusive and in lieu of all other expressed or implied warranties, including, but not limited to, the implied warranties of merchantability and fitness for a particular purpose, shall not extend beyond the duration or the applicable expressed warranties provided herein.

This warranty gives you specific legal rights. You have implied warranty rights. In the event of a problem with warranty service or performance, you may be able to go to small claims court, a state court, or a federal court.

