

## Installation Instructions and Owners Manual

*Congratulations on the purchase of your new water filter featuring the Clydesdale control system. Enjoy lasting peace of mind, knowing your system is built to deliver years of reliable, filtered water.*



## Table of Contents

Installation Information: Your Water Test .....1  
 Pre-Installation Instructions .....2  
 Installation.....3-4  
 Bypass Valve Operation .....5  
 Start Up Instructions .....6  
 Front Cover and Drive Assembly.....7  
 Valve Body Piston Seal Parts Diagram .....8  
 Injector Parts .....9  
 Installer Display Settings.....10  
 User Display Settings.....11-12  
 General System Information.....13  
 Spec Sheet .....14  
 Product Warranty.....15

### ORIGINAL INSTALLATION INFORMATION

Water Treatment Professional: \_\_\_\_\_ Phone: \_\_\_\_\_  
 Installation Date: \_\_\_\_/\_\_\_\_/\_\_\_\_  
 Install location: \_\_\_\_\_  
 Model No: \_\_\_\_\_  
 Serial No: \_\_\_\_\_  
 Water Source:    City    Well    Other  
 Mineral Tank Size:    Diameter \_\_\_\_\_ Height \_\_\_\_\_  
 Time of Regeneration: \_\_\_\_\_ AM    PM  
 DLFC: \_\_\_\_\_ GPM

Your Clydesdale Water Filtering System is a precision built, high quality product. This unit will deliver conditioned water, for many years, when installed and operated properly. Please study this manual carefully. This manual should be kept for future reference.

If you have questions regarding your water filter, contact your local Water Treatment Professional or Charger Water Treatment Products at 8150 N. Lehigh Ave, Morton Grove, IL 60053 • [www.chargerwater.com](http://www.chargerwater.com)

## Pre-Installation Instructions

The manufacturer has preset the water treatment unit's sequence of cycles, including all cycle times. The dealer should read this page and guide the installer regarding day override and time of regeneration, before installation.

For the installer, the following must be used:

- Program Installer Settings: Day Override (preset to 14 days), and Time of Regeneration
- (preset to 12 AM)
- Read Normal Operating Displays
- Set Time of Day
- Read Power Loss & Error Display

For the homeowner, please read operating displays and instructions.



## Installation

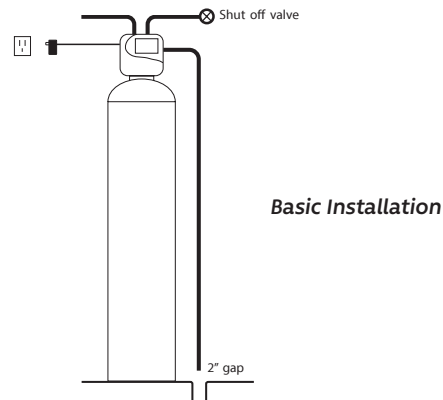
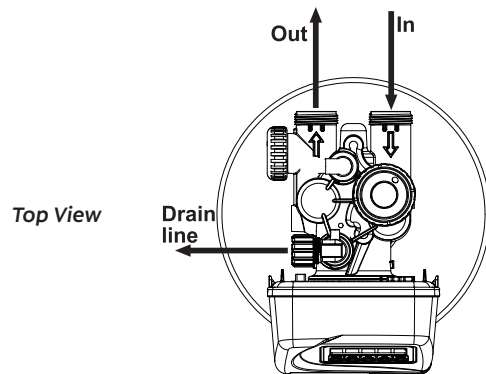

### GENERAL INSTALLATION & SERVICE WARNINGS

The control valve, fittings, and/or bypass are designed to accommodate minor plumbing misalignments but are not designed to support the weight of a system or the plumbing.

Do not use Vaseline, oils, other hydrocarbon lubricants or spray silicone anywhere. A silicone lubricant may be used on black o-rings, but is not necessary.

Do not use pipe dope or other sealants. Only use Teflon tape on threaded connections. The nuts and caps are designed to be unscrewed or tightened by hand or with the special plastic service wrench, V3193-02. If necessary, a pliers can be used to unscrew the nut or cap. Do not use a pipe wrench to tighten or loosen nuts or caps. Do not place screwdriver in slots on caps and/or tap with a hammer.

### SITE REQUIREMENTS:

- Water pressure, 40-90 psi
  - Water temperature, 40°-100°F
  - The tanks should be on a firm, level surface
  - Current draw is 0.25 amperes
  - A 15-foot power cord is furnished
  - The plug-in transformer is for dry locations only
  - Electrical: Use a 115/120v, 60Hz uninterrupted outlet
1. The distance between the drain and the water conditioner should be as short as possible. All plumbing should be done in accordance with local plumbing codes.
  2. Do not install any water conditioner, with less than 10 feet of piping, between its outlet and the inlet of a water heater. Protect system from vacuum, reverse flow, and negative pressure.
  3. Do not locate unit where it or its connections (including the drain and overflow lines) will ever be subjected to room temperatures under 34°F.
  4. **INLET/OUTLET PLUMBING:** Connect to a supply line downstream of outdoor spigots. Install an inlet shutoff valve and plumb to the unit's bypass valve inlet located at the right rear as you face the unit. There are a variety of installation fittings available. They are listed under Installation Fitting Assemblies. When assembling the installation fitting package (inlet and outlet), connect the fitting to the plumbing system first and then attach the nut, split ring, and o-ring. Heat from soldering or solvent cements may damage the nut, split ring, or o-ring. Solder joints should be cool and solvent cements should be set before installing the nut, split ring, and o-ring. Avoid getting solder flux, primer, and solvent cement on any part of the o-rings, split rings, bypass valve, or control valve. If the building's electrical system is grounded to the plumbing, install a copper grounding strap from the inlet to the outlet pipe. Plumbing must be done in accordance with all applicable local codes.

6. **DRAIN LINE:** First, be sure that the drain can handle the backwash rate of the system. Solder joints near the drain must be done prior to connecting the drain line flow control fitting. Leave at least 6" between the drain line flow control fitting and solder joints. Failure to do this could cause interior damage to the flow control. Install a 1/2" I.D. flexible plastic tube to the drain line assembly or the 5/8" O.D. nut assembly and use the 3/4" NPT fitting for larger drain lines. Where the drain line is elevated but empties into a drain below the level of the control valve, form a 7" loop at the discharge end of the line so that the bottom of the loop is level with the drain connection on the control valve. This will provide an adequate anti-siphon trap. Where the drain empties into an overhead sewer line, a sink-type trap must be used. Run drain tube to its discharge point in accordance with plumbing codes. Pay special attention to codes for air gaps and anti-siphon devices.

**IMPORTANT: Never insert a drain line directly into a drain, sewer line, or trap. Always allow an air gap between the drain line and the wastewater to prevent the possibility of sewage being back-siphoned into the conditioner.**

7. **SERIAL NUMBER:** Record the serial number on the installer's and customer's records.
- Bypass Valve - The bypass valve is typically used to isolate the control valve from the plumbing system's water pressure in order to perform control valve repairs or maintenance.

### Bypass Valve

The bypass valve is particularly unique in the water treatment industry due to its versatility and state-of-the-art design features. The 1" full flow bypass valve incorporates four positions including a diagnostic position that allows service personnel to work on a pressurized system while still providing untreated bypass water to the facility or residence. Its completely non-metallic, all plastic design allows for easy access and serviceability without the need for tools.

The bypass body and rotors are fiber reinforced composite and the nuts and caps are glass-filled polypropylene. All seals are self-lubricating EPDM to help prevent valve seizing after long periods of non-use.

The bypass consists of two interchangeable plug valves that are operated independently by red, arrow-shaped handles. The handles identify the flow direction of the water. The plug valves enable the bypass valve to operate in four positions. (See page 5)

1. **Normal Operation Position:** The inlet and outlet handles point in the direction of flow indicated by the engraved arrows on the control valve. Water flows through the control valve during normal operation and this position also allows the control valve to isolate the media bed during the regeneration cycle. (See Figure 1 on page 5)
2. **Bypass Position:** When the inlet and outlet handles point to the center of the bypass, the control valve is isolated from the water pressure contained in the plumbing system. Untreated water is supplied to the plumbing system. (See Figure 2 on page 5)
3. **Diagnostic Position:** The inlet handle points in the direction of flow and the outlet handle points to the center of bypass valve, system water pressure is allowed to the control valve and the plumbing system while not allowing water to exit from the control valve to the plumbing. (See Figure 3 on page 5)
4. **Shut Off Position:** When the inlet handle points to the center of the bypass valve and the outlet handle points in the direction of flow, the water is shut off to the plumbing system. If water is available on the outlet side of the conditioner, it is an indication of water bypass around the system (i.e. a plumbing connection somewhere in the building bypasses the system). (See Figure 4 on page 5)

### Bypass Valve Operation

#### NORMAL OPERATION

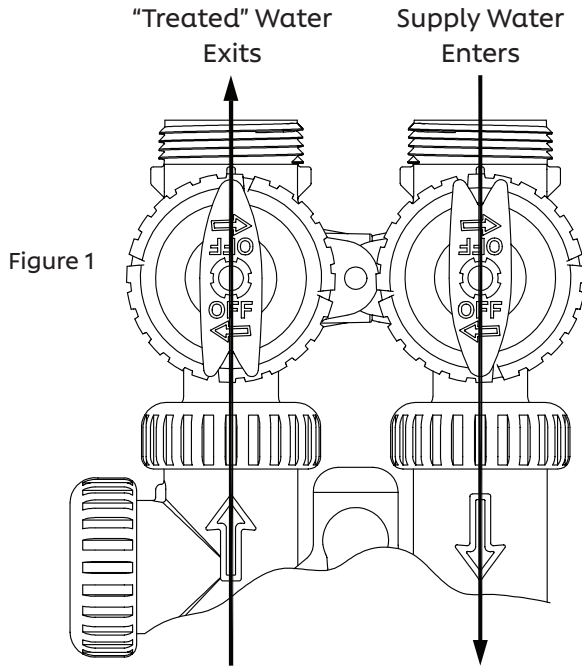

#### BYPASS OPERATION

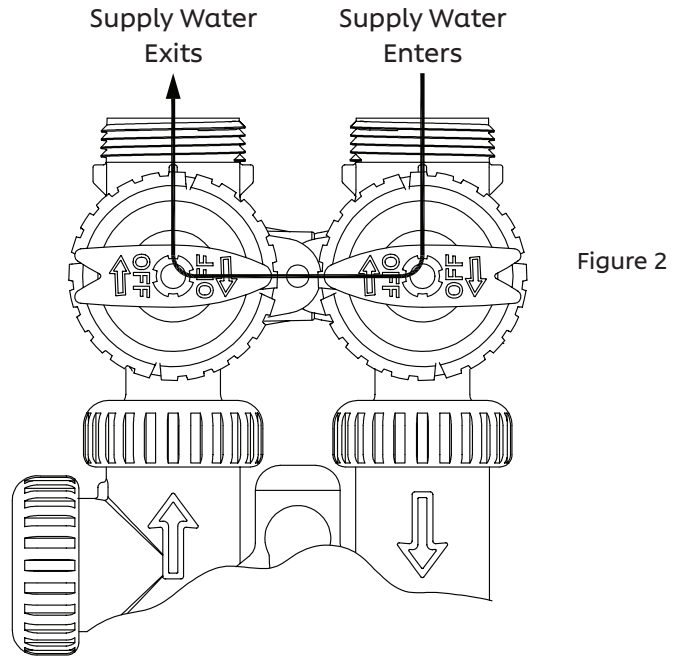

#### DIAGNOSTIC MODE

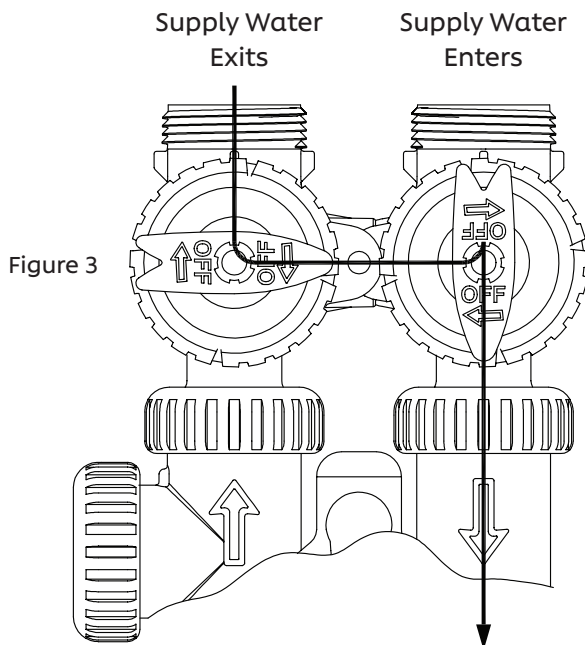

#### SHUT OFF MODE

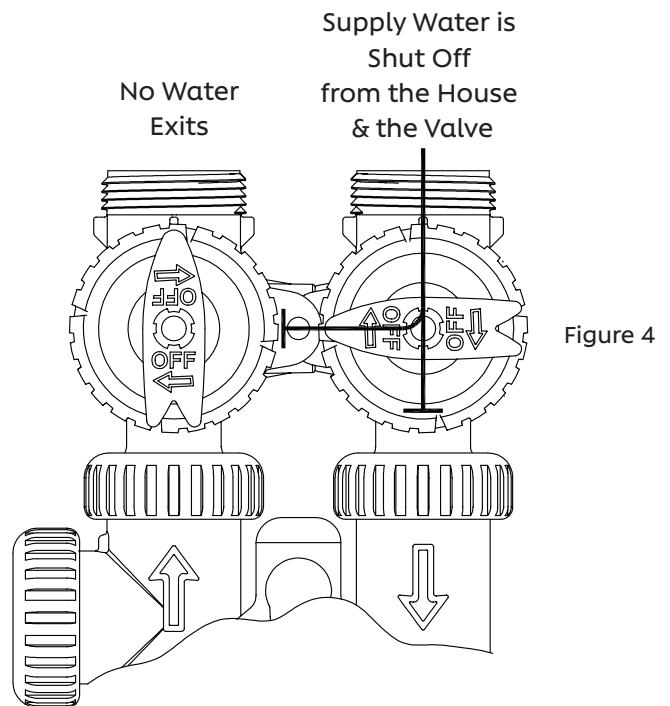

### Start Up Instructions

- A. After installation is completed and checked for leaks, rotate the bypass handles to the bypass position. (See Bypass Valve Diagram on page 5.)
- B. Fully open a cold water faucet.
- C. Allow water to run until clear to rid pipes of debris, which may have occurred during installation.
- D. The system is now ready for testing:
  - 1. With the bypass valve in the bypass position.
  - 2. Press and hold the ▼ and ▲ buttons for about three seconds until the drive motor starts. Wait until the motor stops and the display reads "BACKWASH." The backwash time will begin to count down.
  - 3. Open the inlet handle of the bypass valve, very slightly, allowing water to fill the tank slowly in order to expel air. CAUTION: If water flows too rapidly, there will be a loss of media out of the drain.
  - 4. When the water is flowing steadily to the drain without the presence of air, press the ▲ button to advance the control to the rinse position.
- E. Fully open the inlet bypass valve handle (bypass is now in the Diagnostic Position - see page 5 for illustration). There should be a slow flow to the drain. Allow three minutes for the media bed to settle.

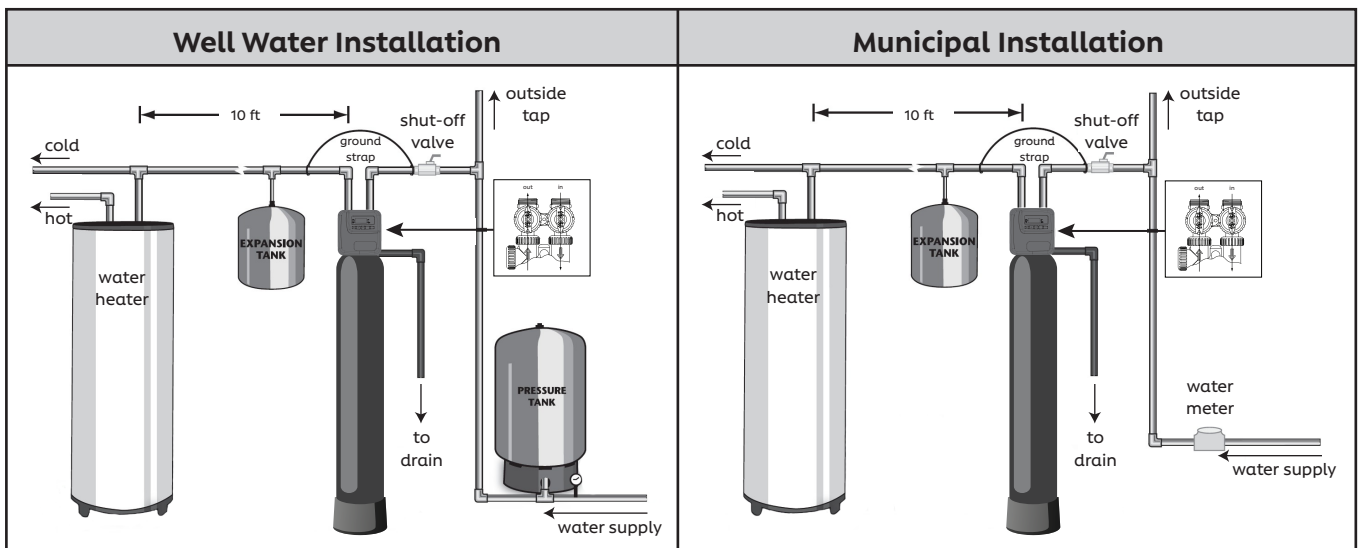

#### Typical Drain Line Installations

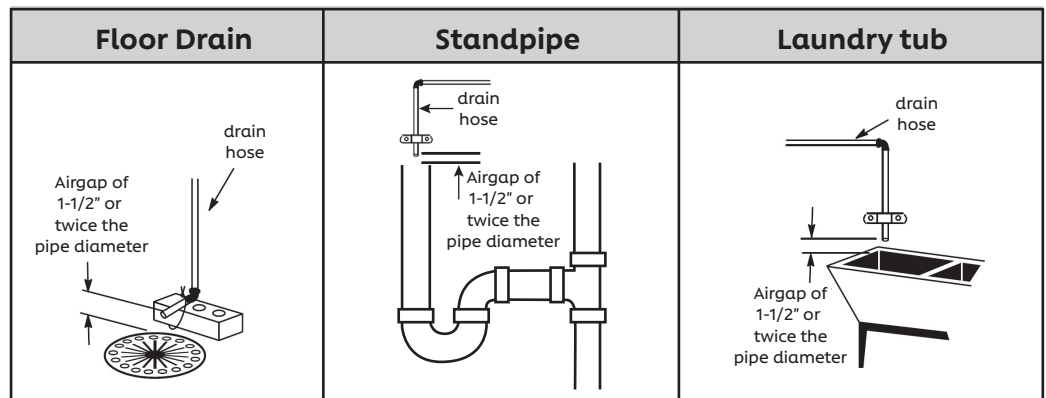

### Front Cover and Drive Assembly

Drawing No.	Order No.	Description	Quantity
1	V3545-02	CT FRONT COVER ASY	1
2	V3107-01	CT MOTOR ASY	1
3	V3002-A	CT DRIVE BRACKET ASY	1
4	V3818CT-01BOARD	CT 4-DIGIT TMC PCB REPLACE	1
5	V3110	CT DRIVE REDUCING GEAR 12X36	3
6	V3109	CT DRIVE GEAR COVER	1
Not Shown	V3186-06	CT POWER SUPPLY US 15VDC HOCP	1
	V3186-01	CT POWER CORD ONLY	

When replacing the battery, align positives and push down to fully seat.

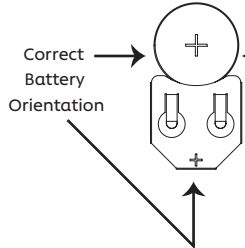
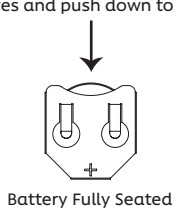

Battery replacement is 3 volt Lithium coin cell type 2032.

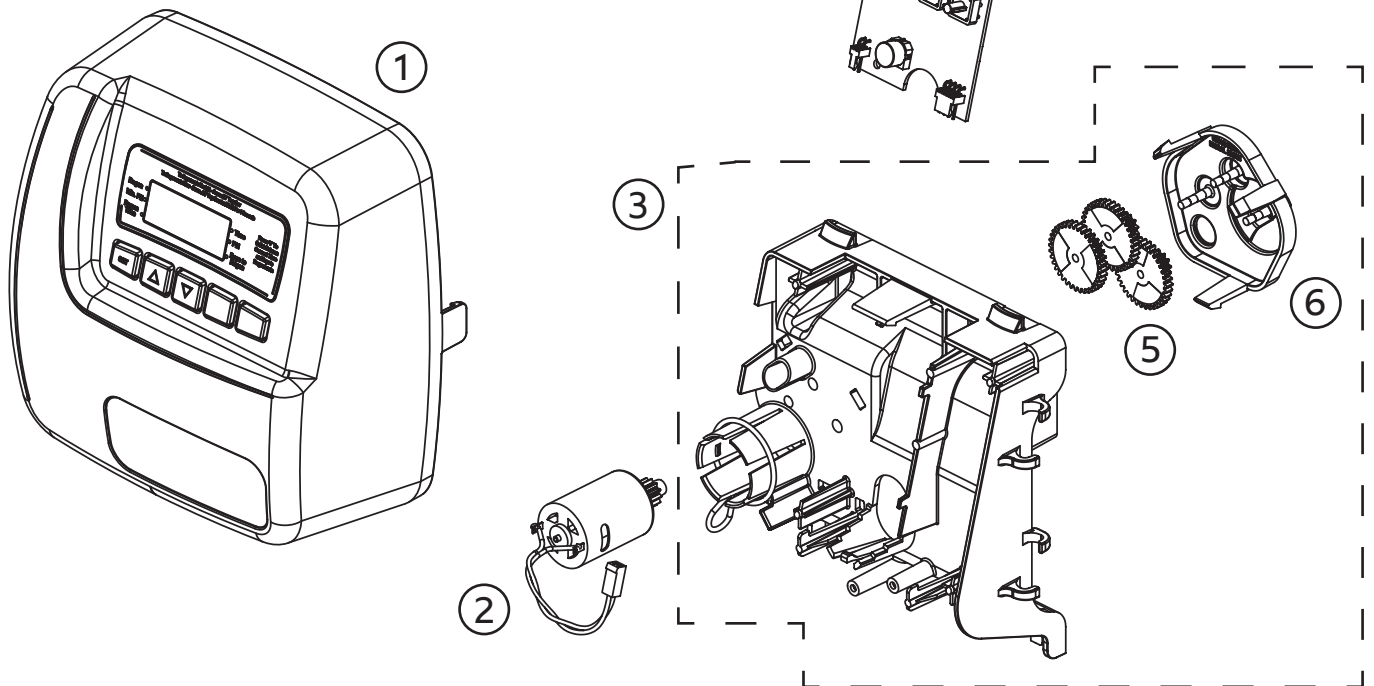

**Valve Body Piston Seal Parts Diagram**

Drawing No.	Order No.	Description	Quantity
1	V3005-02	CT SPACER STACK ASSEMBLY	1
2	V3004	DRIVE CAP ASSEMBLY	1
3	V3178	CT DRIVE BACK PLATE	1
4	V3011*	CT PISTON DOWNFLOW ASSEMBLY	1
5	V3174	CT REGENERANT PISTON	1
6	V3135	O-RING 228	1
7	V3180	O-RING 337	1
8	V3105	O-RING 215 (DISTRIBUTOR TUBE)	1
Not Shown	V3001	CT BODY ASSEMBLY DOWNFLOW	1

\*V3011 is labeled with DN.  
 Note: The regenerant piston is not used in backwash only applications.

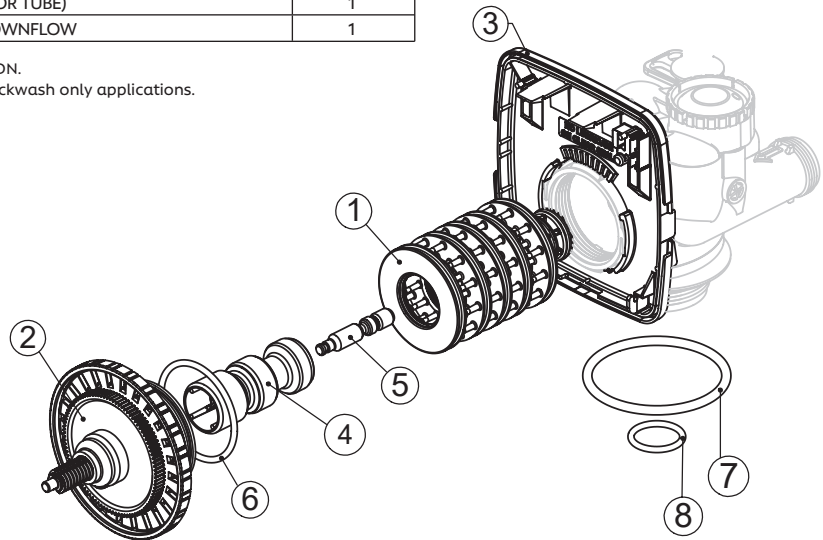

**Injector Cap, Injector Screen, Injector, Plug, and O-Ring**

Drawing No.	Order No.	Description	Quantity
1	V3176	INJECTOR CAP	1
2	V3152	O-RING 135	1
3	V3177-01	INJECTOR SCREEN CAGE	1
4	V3010-1Z	INJECTOR ASSY Z PLUG (2 REQUIRED)	1
Not Shown	V3170	O-RING 011	*
Not Shown	V3171	O-RING 013	*

The injector plug and the injector each contain one 011 (lower) and one 013 (upper) o-ring.

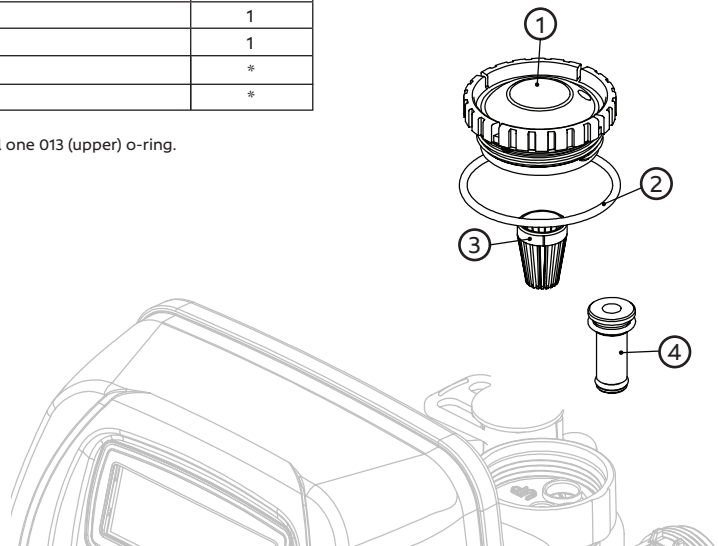

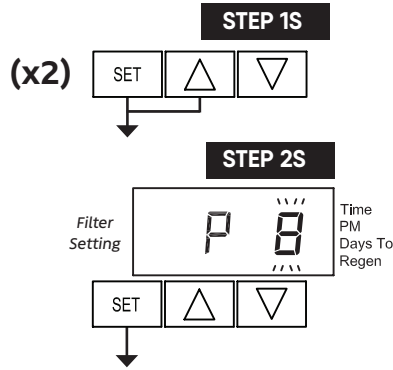

**STEP 1S** - Press SET and ▲ simultaneously for 3 seconds and release. Then press SET and ▲ simultaneously for 3 seconds again and release.

**STEP 2S** - Choose the desired program by pressing ▼ or ▲. Prior to selecting a program, verify the correct valve body, main piston, regenerant piston, and stack are being used, and that the injector or injector plug(s) are in the correct locations. Press SET to go to Step 3S.

P-CODE REGENERATION SEQUENCE/DURATION CHART							
Program Code	All times in Minutes						
	C1 1st Backwash	C2 Downflow Brine Draw	C3 2nd Backwash	C4 Rinse	C5 3rd Backwash	C5 (C6) Fill	C7 Downflow Draw
P0	3	50	3	3	.5	1-99	
P1	8	50	8	4	.5	1-99	
P2	8	70	10	6	.5	1-99	
P3	12	70	12	8	.5	1-99	
P4	10	50		8	.5	1-99	
P5	4	50		4	.5	1-99	
P6	12	6		12	.5	1-99	
P7	6			4			
P8	10			6			
P9	14			8			
P10	12			4			40
P11	15						40
P12	8	25		4			

ERROR CODE CHART	
Description of Error	
E1	Valve not sensing valve motor movement with valve motor energized
E2	Valve motor ran for too short of a time and was unable to find the next valve position - stalled.
E3	Valve motor ran for too long of a time and was unable to find the next valve position.
E4	Nonvolatile memory failure of microprocessor.

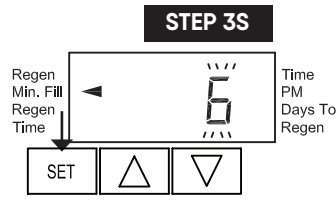

**STEP 3S** - If program P0 - P6 is selected, enter in the minutes of fill using ▼ or ▲. The allowable range is 1-99. This display will not appear if program P7, P8, or P9 is selected. Press SET to go to Step 4S.

*Note: For each minute of fill, 0.5 gallons of water is added to the solution tank. With Sodium Chloride, every 0.5 gallon of water will dissolve 1.5 pounds of salt.*

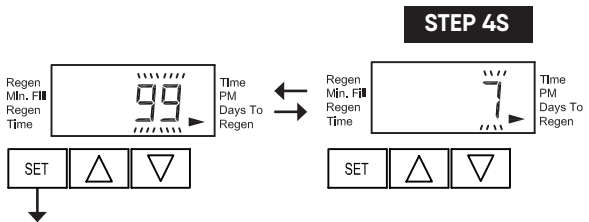

**STEP 4S** - As an energy-saving feature, the control will automatically turn off the display illumination after 5 minutes of keypad inactivity. Any further keypad activity or water use will re-illuminate the display for 5 minutes. The Energy Saver feature default is ON. Press NEXT to exit Installer Display Settings. Press REGEN to return to previous step.

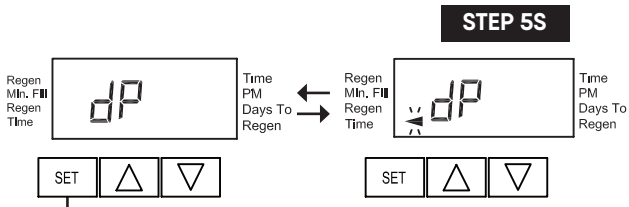

**STEP 5S** - Next regeneration time (hour): Set the hour of day for regeneration using ▼ or ▲. AM/PM toggles after 12. The default time is 12:00AM. Press NEXT to go to Step 6I. Press REGEN to return to previous step.

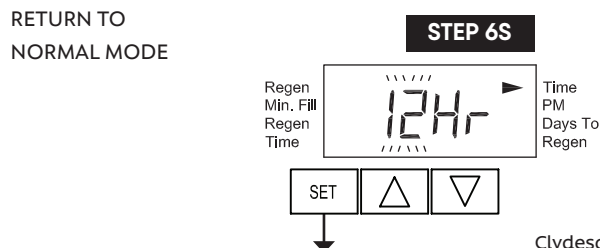

**STEP 6S** - Time keeping format - only viewed when DC power supply is used. Use ▼ or ▲ to select 12 for 12-hour AM/PM format or 24 for 24-hour format. Press SET to exit system setup.

**Installer Displays and Settings  
(1-99 days between regeneration option)**

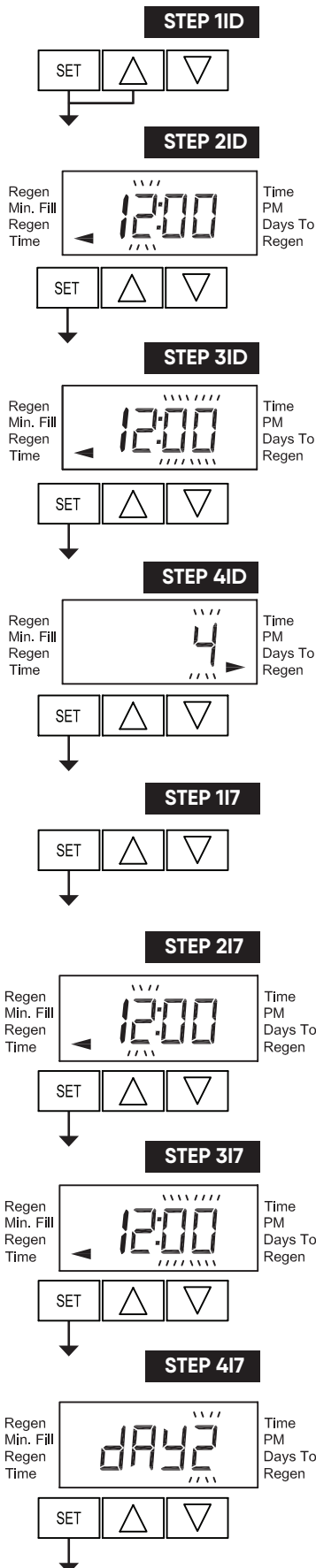

**STEP 11D-** From normal mode, press SET and ▲ simultaneously for 3 seconds and release.

**STEP 21D -** Regeneration Time Hour: Set the time for regeneration to start using ▼ or ▲. Press SET to go to Step 31D.

**STEP 31D -** Regeneration Time Minutes: Set the time for regeneration to start using ▼ or ▲. Press SET to go to Step 41D.

**STEP 41D -** Days to Regen: Set the number of days between regenerations. The allowable range is 1-99. Press SET to exit Installer Displays and Settings.

**Installer Displays and Settings (7-Day Option)**

**STEP 117 -** From normal mode, press SET and ▲ simultaneously for 3 seconds and release.

**STEP 217 -** Regeneration Time Hour: Set the time for regeneration to start using ▼ or ▲. Press SET to go to Set to go to Step 317.

**STEP 317 -** Regeneration Time Minutes: Set the time for regeneration to start using ▼ or ▲. Press SET to go to Step 417.

**STEP 417 -** Current Day of Week: Set the current day of the week by using ▼ or ▲. Press SET to go to Step 517.



**STEP 517- Sunday Regeneration:** To regenerate on Sunday, use ▼ or ▲ until the arrow points to Regen. If the arrow does not point to Regen, a regeneration will not occur on Sunday. Press SET to go to Step 617.



**STEP 617 – Monday Regeneration:** To regenerate on Monday, use ▼ or ▲ until the arrow points to Regen. If the arrow does not point to Regen, a regeneration will not occur on Monday. Press SET to go to Step 717.



**STEP 717 – Tuesday Regeneration:** To regenerate on Tuesday, use ▼ or ▲ until the arrow points to Regen. If the arrow does not point to Regen, a regeneration will not occur on Tuesday. Press SET to go to Step 717.



**STEP 817 – Wednesday Regeneration:** To regenerate on Wednesday, use ▼ or ▲ until the arrow points to Regen. If the arrow does not point to Regen, a regeneration will not occur on Wednesday. Press SET to go to Step 717.



**STEP 917 – Thursday Regeneration:** To regenerate on Thursday, use ▼ or ▲ until the arrow points to Regen. If the arrow does not point to Regen, a regeneration will not occur on Thursday. Press SET to go to Step 717.



**STEP 1017 – Friday Regeneration:** To regenerate on Friday, use ▼ or ▲ until the arrow points to Regen. If the arrow does not point to Regen, a regeneration will not occur on Friday. Press SET to go to Step 717.



**STEP 1117 – Saturday Regeneration:** To regenerate on Saturday, use ▼ or ▲ until the arrow points to Regen. If the arrow does not point to Regen, a regeneration will not occur on Saturday. Press SET to exit Installer Displays & Settings.  
*Note: If all arrows are turned off in d1-d7, the program will default to d7.*

## User Display Settings

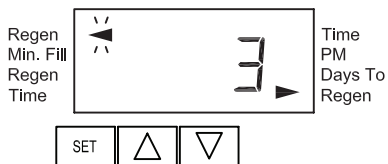
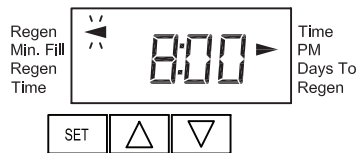

### General Operation

When the system is operating, one of 2 displays will be shown. Pressing ▼ or ▲ will alternate between the displays. One of the displays is always the current time of day. The second display is the days remaining until the next regeneration. If the days remaining is equal to one, a regeneration will occur at the next preset regeneration time. The user can scroll between displays as desired.

If the system has called for a regeneration that will occur at the preset time of regeneration, the arrow will point to Regen.



### Regeneration Mode:

Typically, a system is set to regenerate at a time of low water usage—for example, when a household is asleep. If there is a demand for water when the system is regenerating, untreated water will be used.

When the system begins to regenerate, the display will change to the Regeneration Cycle Display to indicate the current regen cycle step and time remaining. An arrow will also point to Regen. The system will run through the steps automatically and will reset itself to provide treated water when the regeneration is completed.

An arrow will point to the word REGEN if a regeneration is expected "tonight".



### Manual Regeneration

Sometimes, there is a need to regenerate the system sooner than when the system calls for it, usually referred to as a manual regeneration. There may be a period of heavy water usage because of guests or a heavy laundry day.

To initiate a manual regeneration at the preset delayed regeneration time, simultaneously press ▼ and ▲ and release. The arrow will point to the word REGEN if a regeneration is expected "tonight". To cancel the regeneration, simultaneously press ▼ and ▲ and release.

To initiate a manual regeneration immediately, simultaneously press ▼ and ▲ for 3 seconds. The system will begin to regenerate immediately. The request cannot be canceled.

## User Display Settings

### Set Time of Day

STEP 1U – Press SET.

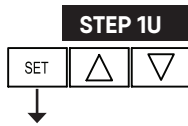

STEP 2U - **Current Time:** Adjust hour with ▼ or ▲. With 60 Hz line frequency detection on power-up, timekeeping is 12-hour with PM indicator. With 50 Hz line frequency detection on power-up, timekeeping is 24-hour without the PM indicator. Press SET to go to 3U.

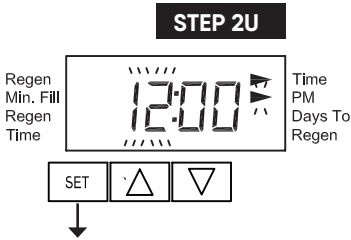

STEP 3U - Adjust minutes with ▼ or ▲. Press SET to exit Set Time of Day.

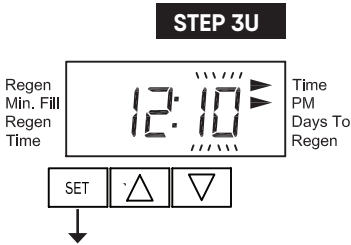



### Power Loss

Only the current time of day will need to be reset if power is lost for more than 8 hours. If power is lost while the system is regenerating, the control will complete regeneration at the point of interruption once power is restored.

### Error Message

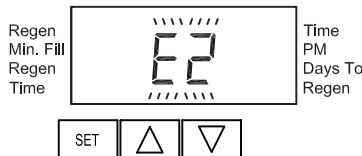
If E1, E2, E3, or E4 appears on the display, contact the OEM for help. This indicates that the valve did not function properly.

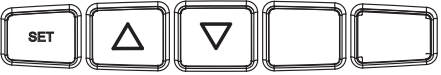

Filtering Model	Model #	Cubic Ft Media	Mineral Tank	SVC (Service) Flow Rate	Backwash Rate
	<b>1" Standard Distributor</b>				
	CTF-948-1	1 cu ft	9 x 48	3 gpm	4.2 gpm
	CTF-1044-1	1.25 cu ft	10 x 44	5 gpm	5.3 gpm
	CTF-1054-1	1.5 cu ft	10 x 54	5 gpm	5.3 gpm
	CTF-1252-1	2 cu ft	12 x 52	7 gpm	6.5 gpm
	CTF-1354-1	2.5 cu ft	13 x 54	9 gpm	9 gpm
	CTF-1465-1	3 cu ft	14 x 65	10 gpm	13 gpm
	CTF-1665-1	4 cu ft	16 x 65	12 gpm	15 gpm
Time Clock 3-Button Valve 					

**MINERAL TANK AVAILABLE COLORS:**

Black, Natural, Almond, Blue, Gray

*Mineral tank jackets are available upon request.*

*Optional outdoor weather covers.*

*Optional dome hole tanks available.*

*Sizing is approximate and can change depending on water usage.*

*Larger systems are available for commercial*

**Typical medias used in the ChargerPro Clydesdale filter systems:**

Anthracite, Birm®, Calcite, Corosex®, Carbon, Filter-Ox™, Filter-Ag®/Filter-Ag Plus®, GreensandPlus™, Katalox Light®, KDF®, & NextSand™.

Other medias are available depending your application. Contact your water treatment professional for more information.

**ChargerPro Clydesdale Valve Benefits**

- Allows for downflow
- Battery time back up (keeps clock accurate in power outage)
- Fully adjustable with up to 3 cycles
- Day override 1-99 days available
- Post-treated water regenerative refill

**ChargerPro Clydesdale - 1" Series Valve Specifications**

Inlet/Outlet (1) ..... 3/4" to 1.5" NPS Adapter  
 Cycles ..... up to 3  
 Valve Material ..... Fiber Reinforced Composite  
 Operating Pressures  
     Minimum/Maximum ..... 20 psi - 125 psi  
 Operating Temperatures  
     Minimum/Maximum ..... 40° - 110°F

## Limited Warranty

Charger Water hereby warrants, to the original purchaser of its water treatment equipment\*, that the control valve is free of defects in materials or workmanship for a period of 60 months for "Clack" controls. Owner shall promptly report to the Installing Retail Company or Charger Water Treatment Products, 8150 N. Lehigh Ave, Morton Grove, IL, any defect in material or workmanship and Charger Water shall, at Charger Water's option, repair or replace the part or parts involved if returned to Charger Water with transportation or freight charges prepaid. No factory labor will be charged for repairing or replacing defective parts during the limited warranty. This warranty shall not apply to any part that has been damaged by improper installation or maintenance, any modification from original design or manufacture, subjected to temperatures below 32°F, above 120°F, operated in water pressure that exceed 120 psi, any water line vacuum, or damaged by any circumstance beyond our control.

**Subject to all conditions and limitations set above, at the site of original installation; any brine tank/cabinet proved defective in material or workmanship will be warranted for a period of 5 years and any residential mineral tank for a period of 10 years.**

*\*All other and/or fittings, brine tank internal components, mineral tank internal components shall be warranted to be free of defects in material and workmanship for a period of one year subject to conditions and limitations set forth above.*

This warranty sets forth Charger Water's sole obligation and purchaser's exclusive remedy for defective product. Charger Water shall not be liable for consequential, incidental, or contingent damages whatsoever.

The forgoing warranties are exclusive and in lieu of all other expressed or implied warranties, including, but not limited to, the implied warranties of merchantability and fitness for a particular purpose, shall not extend beyond the duration or the applicable expressed warranties provided herein.

This warranty gives you specific legal rights. You have implied warranty rights. In the event of a problem with warranty service or performance, you may be able to go to small claims court, a state court, or a federal court.

