

YOUR SYSTEM NAME

Logix

**Models: 268 Co-Current Conditioner
263 Three-Cycle Filter**

Operations Manual

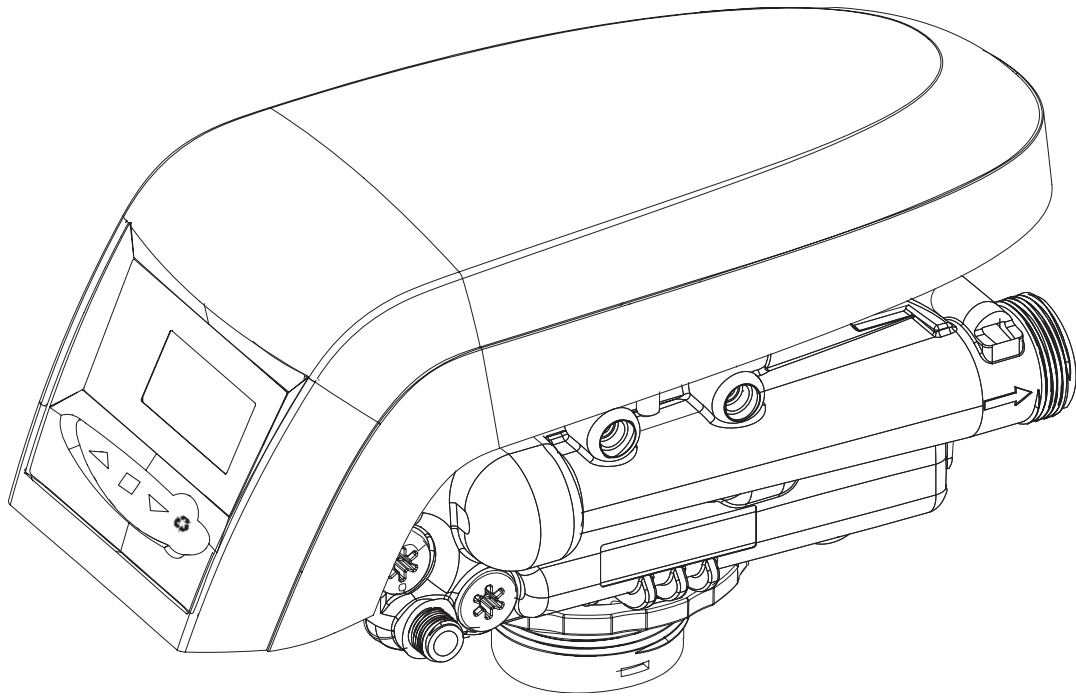

Table of Contents

How To Use This Manual	3
General Warnings And Safety Information	4
System Operation Cycle Functions	6
Equipment Installation	8
Valve Layout	8
Control Layout	9
Location Selection	10
Water Line Connection	11
Drain Line	13
Regenerant Line Connection	14
Overflow Line Connection	15
Electrical Connection	17
Valve Camshaft	18
Disinfection Of Water Conditioners	19
YOUR SYSTEM NAME Logix Controller	20
Display Icons	21
Keypad — Buttons	22
Things You Might Need to Know	23
Programming Overview	24
Level I Programming	25
Level II Programming	26
Level III Programming	30
Placing Conditioner Into Operation	31
Performa Exploded View	34
Performa Parts List	35
Troubleshooting	36

How To Use This Manual

This installation manual is designed to guide the installer through the process of installing and starting conditioners featuring the **YOUR SYSTEM NAME** Logix series controllers.

This manual is a reference and will not include every system installation situation. The person installing this equipment should have:

- Training in the **YOUR SYSTEM NAME** Logix series controllers and Autotrol valves
- Knowledge of water conditioning and how to determine proper control settings
- Basic plumbing skills
- The directional instructions "left" and "right" are determined by looking at the front of the unit.

Left Side

Right Side

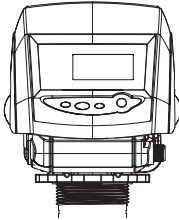

Icons That Appear In This Manual



WARNING: Failure to follow this instruction can result in personal injury or damage to the equipment.



NOTE: This will make the process easier if followed.

Introduction

Inspect the unit for damage or missing parts. Contact your supplier if any discrepancies exist.

General Warnings And Safety Information

Electrical

There are no user-serviceable parts in the AC adapter, motor, or controller. In the event of a failure, these should be replaced.

- All electrical connections must be completed according to local codes.
- Use only the power AC adapter that is supplied.
- The power outlet must be grounded.
- To disconnect power, unplug the AC adapter from its power source.

Mechanical

- Do not use petroleum based lubricants such as vaseline, oils, or hydrocarbon based lubricants. Use only 100% silicone lubricants.
- All plastic connections should be hand tightened. Teflon tape may be used on connections that do not use an O-ring seal. **Do not use pliers or pipe wrenches.**
- All plumbing must be completed according to local codes.
- Soldering near the drain line should be done before connecting the drain line to the valve. Excessive heat will cause interior damage to the valve.
- Observe drain line requirements.
- Do not use lead-based solder for sweat solder connections.
- The drain line must be a minimum of 1/2-inch diameter. Use 3/4-inch pipe if the backwash flow rate is greater than 7 GPM (26.5 Lpm) or the pipe length is greater than 20 feet (6 m).
- Do not support the weight of the system on the control valve fittings, plumbing, or the bypass.
- It is not recommended to use sealants on the threads. Use Teflon* tape on the threads of the 1-inch NPT elbow, the drain line connections, and other NPT threads.

**Teflon is a trademark of E.I. duPont de Nemours.*

General

- Observe all warnings that appear in this manual.
- Keep the media tank in the upright position. Do not turn upside down or drop. Turning the tank upside down will cause media to enter the valve.
- Operating ambient temperature is between 34°F (1°C) and 120°F (49°C).
- Operating water temperature is between 34°F (1°F) and 100°F (38°C).
- Working water pressure range is 20 to 120 psi (1.38 to 8.27 bar). In Canada the acceptable working water pressure range is 20 to 100 psi (1.38 to 6.89 bar).
- Use only regenerant salts designed for water softening. Do not use ice melting, block, or rock salts.
- Follow state and local codes for water testing. Do not use water that is microbiologically unsafe or of unknown quality.
- When filling media tank, do not open water valve completely. Fill tank slowly to prevent media from exiting the tank.
- When installing the water connection (bypass or manifold) connect to the plumbing system first. Allow heated parts to cool and cemented parts to set before installing any plastic parts. Do not get primer or solvent on O-rings, nuts, or the valve.

System Operation Cycle Functions

1. Service (Downflow)

Untreated water is directed down through the resin bed and up through the riser tube. The hardness ions attach themselves to the resin and are removed from the water. The water is conditioned as it passes through the resin bed.

2. Backwash (Upflow)

The flow of water is reversed by the control valve and directed down the riser tube and up through the resin bed. During the backwash cycle, the bed is expanded and debris is flushed to the drain.

3. Brine/Slow Rinse (Downflow)

The control directs water through the brine injector and brine is drawn from the regenerant tank. The brine is then directed down through the resin bed and up through the riser tube to the drain. The hardness ions are displaced by sodium ions and are sent to the drain. The resin is regenerated during the brine cycle. Brine draw is completed when the air check closes.

4. Repressurized Cycle (Hard Water Bypass Flapper Open)

This cycle allows the air and water to hydraulically balance in the valve before continuing the regeneration.

5. Fast Rinse (Downflow)

The control directs water down through the resin bed and up through the riser tube to the drain. Any remaining brine residual is rinsed from the resin bed.

6. Brine Refill

Water is directed down through the resin bed to the regenerant tank at a controlled rate, to create brine for the next regeneration.

Cycle Water Flows

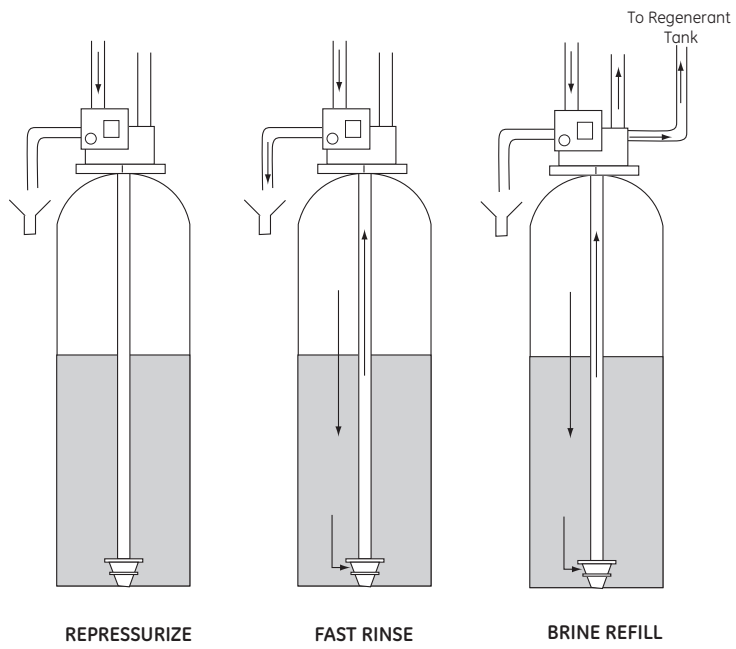
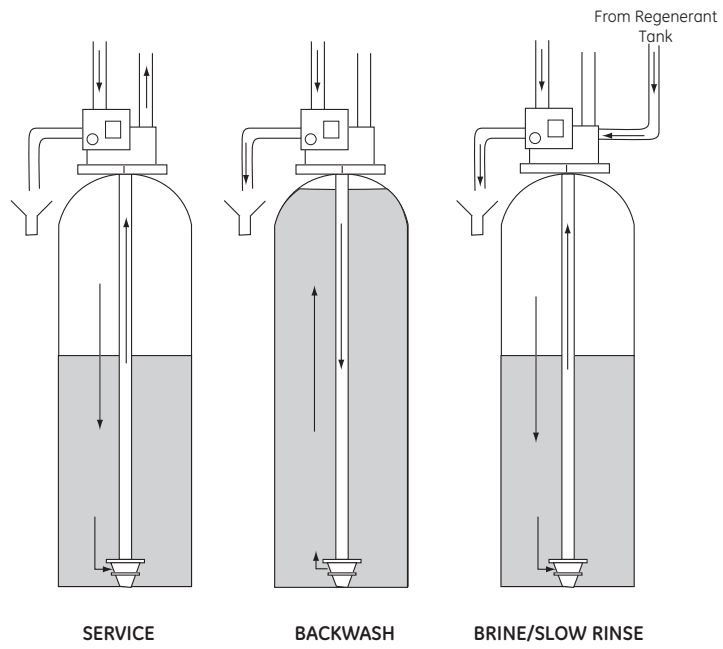

Equipment Installation

Valve Layout

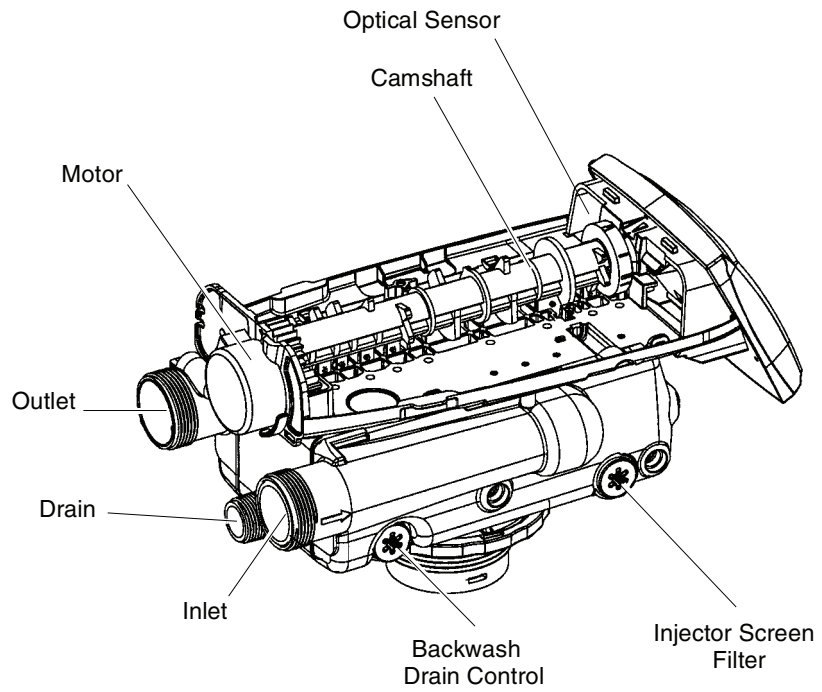
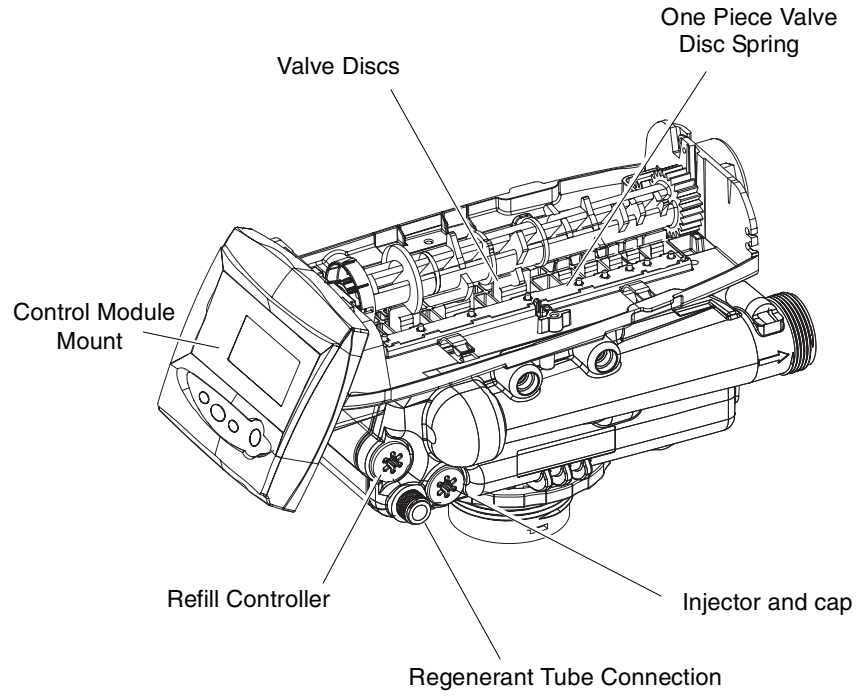

Control Layout

YOUR SYSTEM NAME Logix Controller

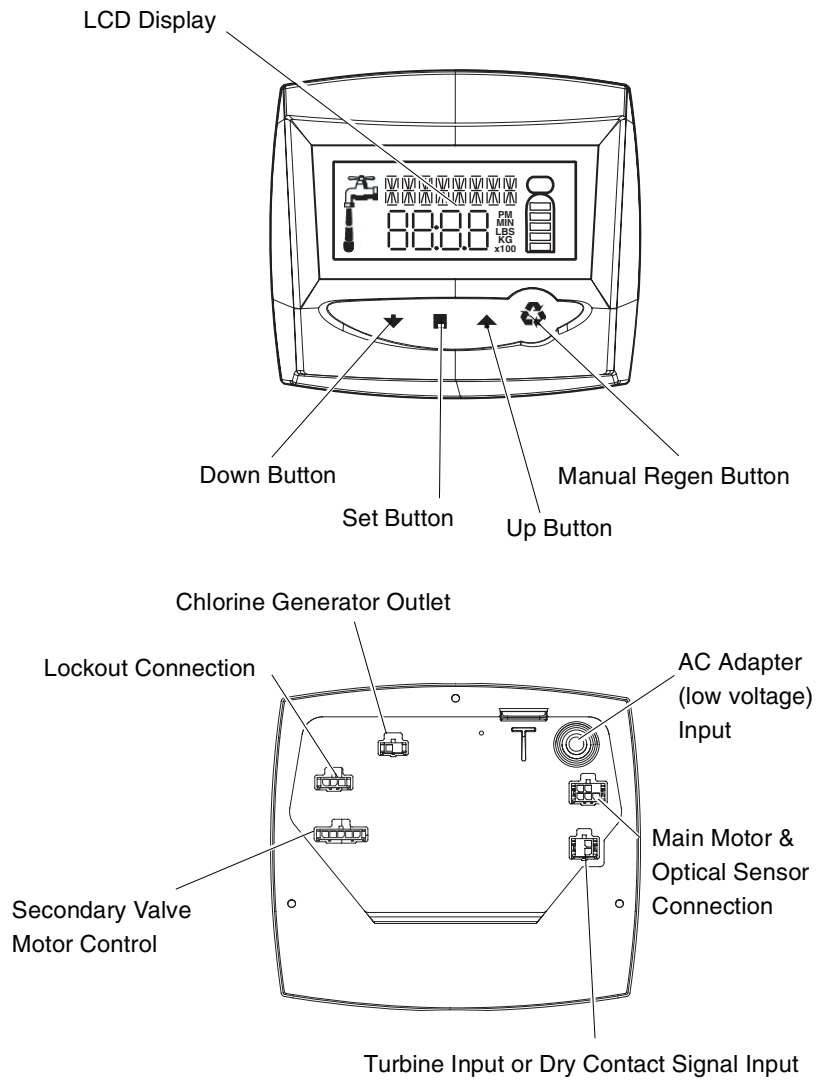

Location Selection

Location of a water treatment system is important. The following conditions are required:

- Level platform or floor
- Room to access equipment for maintenance and adding regenerant (salt) to tank.
- Ambient temperatures over 34°F (1°C) and below 120°F (49°C).
- Water pressure below 120 psi (8.27 bar) and above 20 psi (1.4 bar).
- In Canada the water pressure must be below 100 psi (6.89 bar).
- Constant electrical supply to operate the controller.
- Total minimum pipe run to water heater of ten feet (three meters) to prevent backup of hot water into system.
- Local drain for discharge as close as possible.
- Water line connections with shutoff or bypass valves.
- Must meet any local and state codes for site of installation.
- Valve is designed for minor plumbing misalignments. Do not support weight of system on the plumbing.
- Be sure all soldered pipes are fully cooled before attaching plastic valve to the plumbing.

Outdoor Locations

When the water conditioning system is installed outdoors, several items must be considered.

- **Moisture** — The valve and controller are rated for NEMA 3 locations. Falling water should not affect performance.
The system is not designed to withstand extreme humidity or water spray from below. Examples are: constant heavy mist, near corrosive environment, upwards spray from sprinkler.
- **Direct Sunlight** — The materials used will fade or discolor over time in direct sunlight. The integrity of the materials will not degrade to cause system failures.
If it is necessary to locate the conditioner in direct sunlight, a protective outdoor cover (PN 1267811) over the valve and controller is necessary. A valve skirt (PN 1267808) that provides further protection is available.
- **Temperature** — Extreme hot or cold temperatures will cause damage to the valve or controller.
Freezing temperatures will freeze the water in the valve. This will cause physical damage to the internal parts as well as the plumbing.
High temperatures will affect the controller. The display may become unreadable but the controller should continue to function. When the temperature drops down into normal operating limits the display will return to normal. A protective cover should assist with high temperature applications.
- **Insects** — The controller and valve have been designed to keep all but the smallest insects out of the critical areas. Any holes in the top plate can be covered with a metal foil ductwork tape. The top cover should be installed securely in place.
- **Wind** — The Logix cover is designed to withstand a 30 mph (48 Kph) wind when properly installed on the valve.

Water Line Connection

A bypass valve system should be installed on all water conditioning systems. Bypass valves isolate the conditioner from the water system and allow unconditioned water to be used. Service or routine maintenance procedures may also require that the system is bypassed. The illustrations below show the two common bypass methods.

Figure 1
Autotrol Series 1265
bypass for use with
Performa

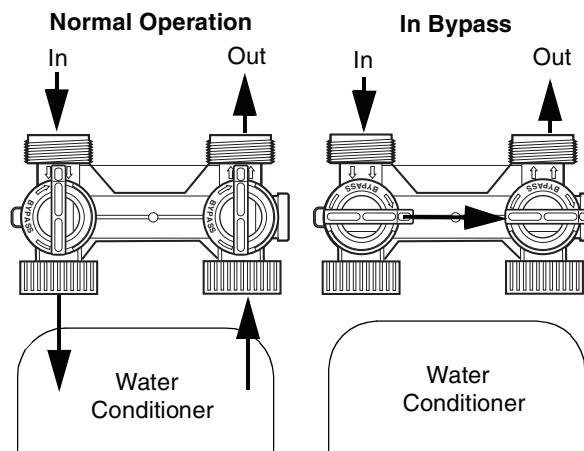
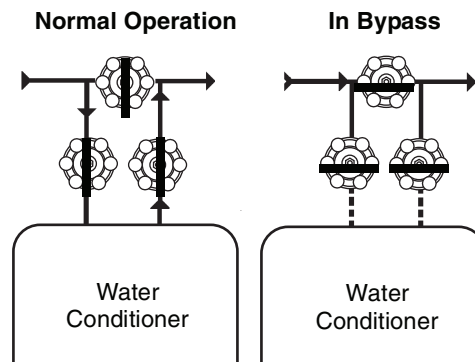

Figure 2
Typical Globe Valve
Bypass System



WARNING: The inlet water must be connected to the inlet port of the valve. When replacing non-Autotrol valves, the inlet and outlet may be reversed. It is also possible for the plumbing to be installed in an opposite order.
Do not solder pipes with lead-based solder.



WARNING: Do not use tools to tighten plastic fittings. Over time, stress may break the connections. When the 1265 bypass valve is used, only hand tighten the nuts.



WARNING: Do not use petroleum grease on gaskets when connecting bypass plumbing. Use only 100% silicone grease products when installing any Autotrol valve. Non-silicone grease may cause plastic components to fail over time.



WARNING: Several tube adapters are available to connect the valve to the water plumbing. See *Parts List*.

Drain Line

Drain Line Connection



NOTE: Standard commercial practices are expressed here. Local codes may require changes to the following suggestions. Check with local authorities before installing a system.

1. The unit should be above and not more than 20 feet (6.1 m) from the drain. Use an appropriate adapter fitting to connect 1/2-inch (1.3 cm) plastic tubing to the drain line connection of the control valve.
2. If the backwash flow rate exceeds 5 gpm (22.7 Lpm) or if the unit is located 20-40 feet (6.1-12.2 m) from drain, use 3/4-inch (1.9 cm) tubing. Use appropriate fittings to connect the 3/4-inch tubing to the 3/4-inch NPT drain connection on valve.
3. The drain line may be elevated up to 6 feet (1.8 m) providing the run does not exceed 15 feet (4.6 m) and water pressure at the conditioner is not less than 40 psi (2.76 bar). Elevation can increase by 2 feet (61 cm) for each additional 10 psi (.69 bar) of water pressure at the drain connector.
4. Where the drain line is elevated but empties into a drain below the level of the control valve, form a 7-inch (18-cm) loop at the far end of the line so that the bottom of the loop is level with the drain line connection. This will provide an adequate siphon trap.

Where the drain empties into an overhead sewer line, a sink-type trap must be used.

Secure the end of the drain line to prevent it from moving.

Figure 3
Drain Line Connection

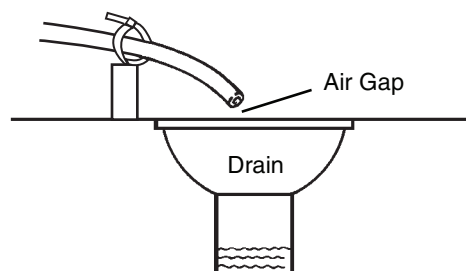

WARNING: Never insert drain line directly into a drain, sewer line or trap (Figure 3). Always allow an air gap between the drain line and the wastewater to prevent the possibility of sewage being back-siphoned into the conditioner.

Regenerant Line Connection

(not used with 3-cycle filter system)

The regenerant line from the tank connects to the valve. Make the connections and hand tighten. Be sure that the regenerant line is secure and free from air leaks. Even a small leak may cause the regenerant line to drain out, and the conditioner will not draw regenerant from the tank. This may also introduce air into the valve causing problems with valve operation.

Ensure that pipe sealant (Teflon* tape) is applied to the 3/8-inch NPT regenerant line connection.

Figure 4 Regenerant
Line Connection

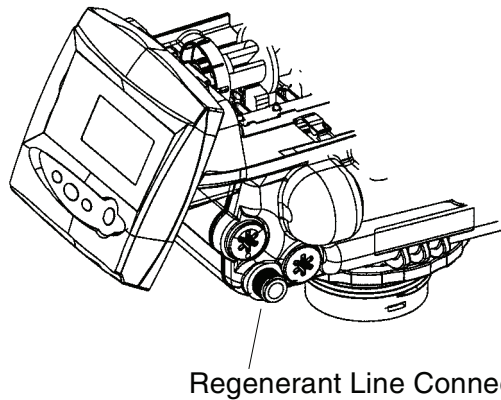

NOTE: When installing a 3-cycle filter (263 valve) use a cap on the regenerant line connection to prevent water seepage from the port. See *Parts List* for part number.

**Teflon is a trademark of E.I. duPont de Nemours.*

Overflow Line Connection

(not used with 3-cycle filter system)

In the event of a malfunction, the regenerant TANK OVERFLOW will direct “overflow” to the drain instead of spilling on the floor. This fitting should be on the side of the cabinet or regenerant tank. Most tank manufacturers include a post for the tank overflow connector.

To connect the overflow line, locate hole on side of tank. Insert overflow fitting into tank and tighten with plastic thumb nut and gasket as shown (Figure 5). Attach length of 1/2-inch (1.3-cm) I.D. tubing (not supplied) to fitting and run to drain. Do not elevate overflow line higher than overflow fitting.

Do not tie into drain line of control unit. Overflow line must be a direct, separate line from overflow fitting to drain, sewer or tub. Allow an air gap as per drain line instructions.

Figure 5
Overflow Line Connection

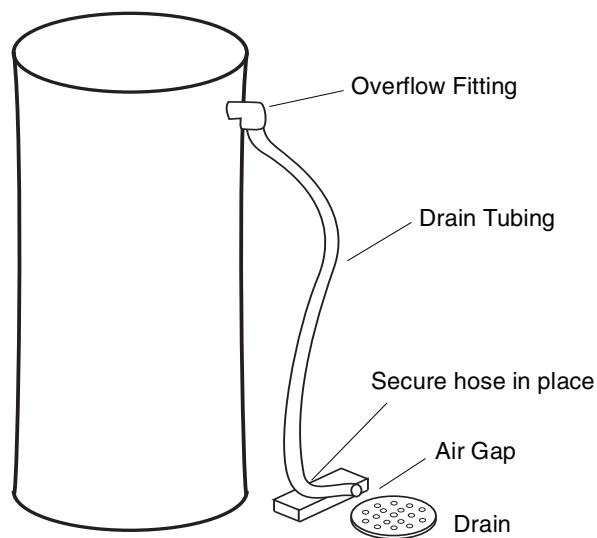
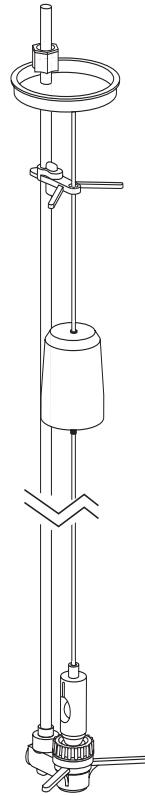

Figure 6
Regenerant Tank Check Valve*
(not used with 3-cycle filter system)



* Furnished as an option from system manufacturer.

Electrical Connection

CAUTION: This valve and control are for dry location use only unless used with a Listed Class 2 power supply suitable for outdoor use.

All Logix controllers operate on 12-volt alternating current power supply. This requires use of the Pentair Water supplied AC adapter. A variety of AC adapters are available for different applications. These AC adapters are available from your supplier. They include:

AC Adapter	Input Voltage	Application	Part Number
Standard wall-mount AC adapter	120V 60Hz	Standard indoor application	1000811
Outdoor rated AC adapter	120V 60Hz	UL listed for outdoor installations	1235448

120 VAC AC Adapters:

Make sure power source matches the rating printed on the AC adapter.



NOTE: The power source should be constant. Be certain the AC adapter is not on a switched outlet. Power interruptions longer than 8 hours may cause the controller to lose the time and day settings. When power is restored, the day and time settings must then be re-entered.

Controller Location

The Logix controllers are designed to be mounted on the valve or attached to a flat surface. Installations that do not provide easy access to the valve can have the controller mounted for remote operation.

A remote mount connection, PN 1256257, is available for the **YOUR SYSTEM NAME** Logix Series controller.

Valve Camshaft

The front end of the camshaft has an indicator cup. The cup has slots in the outer periphery and numbers on the inside face (Figure 7).

The numbers can be seen with the cover off, from the front over the top of the controller. The number at the top indicates which regeneration cycle is currently in progress.

Figure 7
Camshaft Front End for
263 and 268 valve bodies

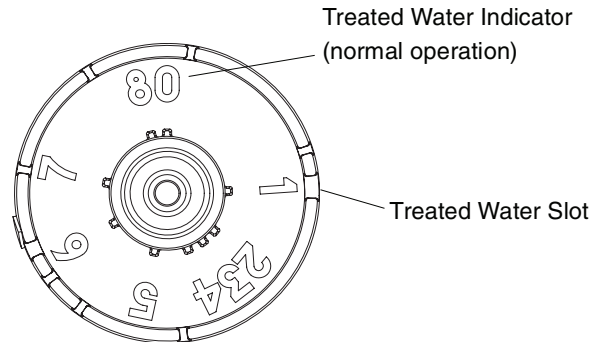

The corresponding slot for the number is positioned at the optical sensor which is approximately 90 degrees out of phase.

Regeneration Cycle Indicators

- 0 = Treated Water - normal operation mode
- 1 = Backwash Cycle
- 2 = Regenerant Draw Cycle (not used in filter mode)
- 3 = Slow Rinse Cycle (not used in filter mode)
- 4 = System Pause
- 5 = Fast Rinse Cycle 1
- 6 = Backwash Cycle 2 (not used in filter mode)
- 7 = Fast Rinse Cycle 2 (not used in filter mode)
- 8 = Regenerant Refill (not used in filter mode)

Valve Disc Operation

Figure 8 - Performa Valve

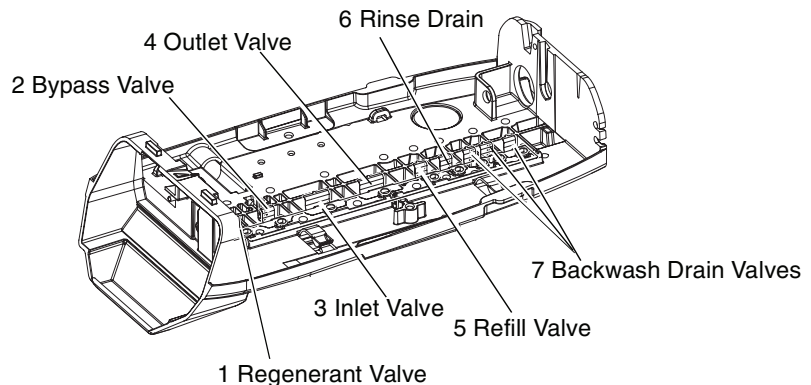

Disinfection Of Water Conditioners

The materials of construction of the modern water conditioner will not support bacterial growth, nor will these materials contaminate a water supply. During normal use, a conditioner may become fouled with organic matter, or in some cases with bacteria from the water supply. This may result in an off-taste or odor in the water.

Some conditioners may need to be disinfected after installation and some conditioners will require periodic disinfection during their normal life.

Depending upon the conditions of use, the style of conditioner, the type of ion exchanger, and the disinfectant available, a choice can be made among the following methods.

Sodium or Calcium Hypochlorite Application

These materials are satisfactory for use with polystyrene resins, synthetic gel zeolite, greensand and bentonites.

5.25% Sodium Hypochlorite

These solutions are available under trade names such as Clorox*. If stronger solutions are used, such as those sold for commercial laundries, adjust the dosage accordingly.

1. Dosage
 - A. Polystyrene resin; 1.2 fluid ounce (35.5 mL) per cubic foot.
 - B. Non-resinous exchangers; 0.8 fluid ounce (23.7 mL) per cubic foot.
2. Brine tank conditioners
 - A. Backwash the conditioner and add the required amount of hypochlorite solution to the well of the regenerant tank. The regenerant tank should have water in it to permit the solution to be carried into the conditioner.
 - B. Proceed with the normal regeneration.

*Clorox is a trademark of the Clorox Company.

Calcium Hypochlorite

Calcium hypochlorite, 70% available chlorine, is available in several forms including tablets and granules. These solid materials may be used directly without dissolving before use.

1. Dosage
 - A. Two grains (approximately 0.1 ounce [3 mL]) per cubic foot.
2. Regenerant tank conditioners
 - A. Backwash the conditioner and add the required amount of hypochlorite to the well of the regenerant tank. The regenerant tank should have water in it to permit the chlorine solution to be carried into the conditioner.
 - B. Proceed with the normal regeneration.

Power Loss Memory Retention

The Logix series controllers feature battery-free time and date retention during the loss of power. This is designed to last a minimum of 8 hours depending on the installation. The controller will continue to keep time and day in dynamic memory while there is no AC power.

The controller will not track water usage on volumetric demand controls in the event of a power failure.

All programmed parameters are stored in the Logix series static memory and will not be lost in the event of a power failure. These settings are maintained separately from the time and day settings.

Motor

The Logix series controller uses a standard 12-volt AC motor that works with either 50 Hz or 60 Hz. The same motor is used worldwide and does not need to be changed for different power conditions.

Controller Memory

Information entered or calculated by the controller is stored in two different ways.

A static memory will store:

- Model number
- Regenerant setting
- Time of regeneration
- Days between regeneration
- Filter mode

A dynamic memory with 8 hour retention will store:

- Current day of week
- Running clock



NOTE: Water flow to the valve can be turned on or bypassed when the controller is powered up for the first time.

Variable Reserve Function

The Logix metered-demand volumetric controllers are designed with a variable reserve feature. This feature automatically adjusts the reserve to the end-user's water usage schedule.

A variable reserve saves salt and water by only regenerating when absolutely necessary, and ensures enough soft water for typical high-water usage days.

Each day of regeneration the controller reviews the last four weeks of water usage for the same day of the week to determine if the remaining capacity is adequate for the next day of the week. If not, it will initiate an automatic regeneration.

Display Icons

Figure 9

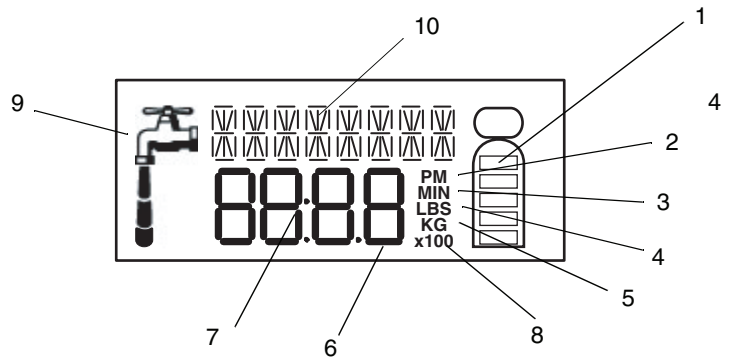

NOTE: In normal operation and during programming, only a few of the icons will actually be displayed.

1. Displays amount of conditioning capacity remaining.
2. "PM" indicates that the time displayed is between 12:00 noon and 12:00 midnight (there is no AM indicator). PM indicator is not used if clock mode is set to 24-hour.
3. When "MIN" is displayed, the value entered is in minute increments.
4. When "LBS" is displayed, the value entered is in pounds.
5. When "Kg" is displayed, the value entered is in kilograms or kilograins.
6. Four digits used to display the time or program value. Also used for error codes.
7. Colon flashes as part of the time display. Indicates normal operation.
8. X100 multiplier for large values.
9. Shows when water is flowing through the valve.
10. Banner display.

Keypad — Buttons

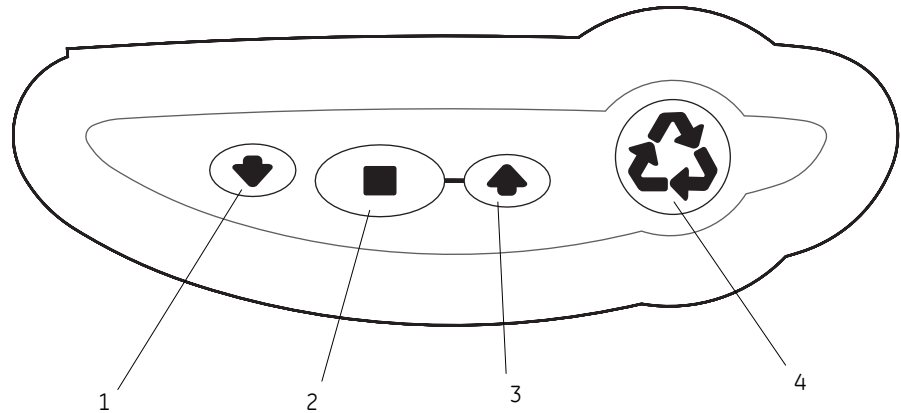

1. DOWN arrow. Generally used to scroll down or increment through a group of choices.
2. SET. Used to accept a setting that normally becomes stored in memory. Also used together with the arrow buttons.
3. UP arrow. Generally used to scroll up or increment through a group of choices.
4. Regen. Used to command the controller to regenerate.

Programming Conventions

The **YOUR SYSTEM NAME** Logix controller is programmed using the buttons on the keypad. The programming instructions will be described two ways whenever a section has keypad input.

First, a table shows simplified instructions. Second, text follows that describes the action. In each table:

"Action" lists the event or action desired.

"Keys" are listed as:

UP for up arrow
DOWN for down arrow
SET for set
REGEN for regeneration

"Duration" describes how long a button is held down:

P/R for press and release
HOLD for press and hold
X sec for a number of seconds to press the button and hold it down

"Display" calls out the display icons that are visible.

Things You Might Need to Know

- When the controller is first plugged in, it may display a flashing Err 3 and scrolling "Call Dealer for Service" message. This means that the controller is rotating to the home position. The Err 3 will clear when the control reaches the home position.
- The preset default time of regeneration is 2:00 AM. If you want to change it, see the *Level II Programming* section.
- The controller can be programmed to regenerate on specific days of the week. See *Level II Programming* section.
- If electrical power is not available, the camshaft can be rotated counterclockwise by hand if the motor is removed.
- The **YOUR SYSTEM NAME** Logix series controller sends commands to the motor for camshaft movement. However, water pressure/flow are required during the regeneration cycle for backwash, purge and refill, and brine draw to actually take place.
- Make sure control power source is plugged in. The transformer should be connected to a non-switched power source.

Programming Overview

The **YOUR SYSTEM NAME** Logix Series controller is designed to operate by setting the Time of Day, Day of the Week, and the Hardness. The remaining settings are set at the factory using a Model Number.

The controller menu has three levels:

Level I Basic — This level is easily accessed by the user. Only the Time of Day, Day of Week and Time of Regeneration can be changed in Level I.

Level II Professional — This level allows the installer to change settings such as hardness, capacity, and cycle times.

Level III History — This operation history and the program are viewable. This information is used to troubleshoot and maintain the system.



NOTE: If a button is not pushed for thirty seconds, the controller returns to normal operation mode.



NOTE: Any setting that is a time display will not show "AM" for times between 12:00 midnight and 12:00 noon. "PM" is displayed to the right of the time for times between 12:00 noon and 12:00 midnight. When using the 24 hour clock "PM" is not displayed.

Level I Programming

Level I program parameters are those that can be accessed by the end user by pressing the SET button. They include:

Time of Day
Day of Week
Time of Regeneration

- **Setting Time of Day**

Upon initial start up of the controller, you will need to set the time of day. The words "Time of Day" will scroll across the banner display and the currently programmed time of day will be flashing below. If time is not flashing, press the SET button. To change the time of day, press and hold the UP or DOWN button until the correct time of day is displayed. Press the SET button to accept the selection.



NOTE: When the controller is set up for a twelve hour clock a PM indicator will illuminate when the displayed time is in the PM hours. There is no AM indicator

- **Setting Day of Week**

After setting the Time of Day the banner display will show the word "Day" followed by an abbreviated day of the week.

SU = Sunday
MO = Monday
TU = Tuesday
WE = Wednesday
TH = Thursday
FR = Friday
SA = Saturday

Use the UP or DOWN arrow buttons to change the flashing day of week. Press the SET button when the current day of week is flashing.

- **Setting Regeneration Time**

The "Regeneration Time" is the setting which allows the programmer to select the time of day that regeneration should occur. The words "Regeneration Time" will scroll through the banner display. To change the regeneration time press and hold the UP or DOWN button until the desired regeneration time is displayed. Press SET to lock this time into memory.



NOTE: When the controller is set up for a twelve hour clock a PM indicator will illuminate when the displayed time is in the PM hours. There is no indicator for the AM times.

Level II Programming

Level II program parameters are those parameters used to fine-tune a conditioners operation. These are accessible by pressing and holding the UP and DOWN buttons until the display goes blank. Then release the buttons. Calendar Override is the first Level II parameter displayed. Level II program parameters include:

268 Conditioner Operation Type

CALENDAR OVERRIDE
SALT AMOUNT
CAPACITY K GRAIN
HARDNESS GPG
SELECT LANGUAGE
CLOCK MODE
UNITS OF MEASURE
INJECTOR SELECTION*
BACKWASH 1
SLOW RINSE
FAST RINSE 1
BACKWASH 2
FAST RINSE 2
OPERATION TYPE 268*
SERVICE INTERVAL
CHLORINE GENERATOR

263 Filter Operation Type

CALENDAR OVERRIDE
REGEN SU
REGEN MO
REGEN TU
REGEN WE
REGEN TH
REGEN FR
REGEN SA
CAPACITY GAL
SELECT LANGUAGE
CLOCK MODE
UNITS OF MEASURE
BACKWASH
FAST RINSE
OPERATION TYPE 263*
SERVICE INTERVAL
CHLORINE GENERATOR

*View only.

Level II parameters will, in almost all cases, be preset to meet your configuration needs. The predefined system number will preprogram all of the Level II parameters to the selected default values.

- **Setting the Calendar Override**

Calendar Override allows the programmer to set the maximum days between regenerations. A setting of 0 (zero) means the calendar override is disabled. To change the calendar override, press the SET button while the words "CALENDAR OVERRIDE" appear on the banner display. The blinking digit can be changed to the desired numbers of days. To lock in the parameter, press the SET button.



WARNING: Setting days between regeneration to zero will cause the system to not regenerate. This setting is used for selecting regeneration on specific days or to use with a remote regeneration input. See below.



NOTE: Regeneration on specific day is used to provide regeneration when water demands are not steady. Example: If the weekdays have low usage and the weekend is high, then regeneration every three days will not meet the requirements.

The calendar override days between regeneration must be set to zero to enable regeneration on specific days.

- **Setting Backwash Days (263 filter only)**

The 263 filter controller can be programmed to regenerate on an elapsed time period (calendar override) or by the day of the week. If you would like to regenerate on specific days select a 0 (zero) for the calendar override setting, the 263 filter will prompt you to select the days of the week in which you would like the unit to regenerate/backwash. For example, the unit could be programmed to regenerate every Monday, Wednesday and Friday.

- **Setting the Salt Amount (268 softener only)**

Is selected by the system model number. Your **YOUR SYSTEM NAME** Water Treatment Dealer enters the model numbers based on the specific application requirements.

- **Setting Capacity**

- **Softener Default Capacity Setting**

- The default capacity setting is accurately calculated when the model number is entered by the factory. The capacity can be changed to operate "custom systems". Contact your **YOUR SYSTEM NAME** Water Treatment Dealer before adjusting the capacity setting. Default capacities are shown in Table 1.

- **Filter Capacity**

- Filter capacity is set in gallons or cubic meters. It is programmable from 100 to 14000 gallons or 1 to 140 cubic meters of capacity. Press the SET button and the digits will begin flashing. Change the capacity by using the up and down arrows to adjust the setting. To accept the setting, press the SET button.



NOTE: (Conditioners only) A different model number must be selected to change the default capacity and salt dosage.

- **Setting the Hardness (conditioner only)**

Hardness is set in grains per gallon (gpg) or parts per million (ppm) and should be programmed to the total hardness level of the incoming water supply. Press the SET button to make the display flash. Use the UP and DOWN buttons to adjust the hardness setting. Press the SET button when the desired setting has been reached.

- **Setting the Language**

The controller is capable of displaying 6 different languages. They are as follows:

- 1 = English
- 2 = Spanish
- 3 = French
- 4 = Italian
- 5 = Flemish
- 6 = German

Press the SET button and select the desired language using the UP or DOWN buttons. Press the SET button to accept the selection.

- **Setting Clock Mode**

The controller can be programmed to operate with a 12- or 24-hour clock. Program the clock mode to "12" for a 12-hour clock or "24" for a 24-hour clock. When the controller is programmed as a 12-hour clock the PM indicator will illuminate during the PM hours. There is no AM indicator.

- **Setting Units of Measure**

The controller can be programmed to operate in U.S. or Metric units. Program the Units of Measure to 0 (zero) for U.S. units or 1 for Metric units.

- **Viewing the Injector Type**

Is selected by system model number and cannot be changed.

- **Adjusting the Cycle Times**

Conditioner Cycle Times

The following cycle times are adjustable.

268 Conditioner

Cycle	Range
Backwash 1	1-60 minutes
Slow Rinse *	1-125 minutes
Fast Rinse 1	1-30 minutes
Backwash 2	0-30 minutes
Fast Rinse 2	0-30 minutes

263 Filter Cycle Times

Cycle	Range
Backwash	1-50 minutes
Fast Rinse	1-30 minutes

Refill time does not appear as this cycle time is determined by the salt setting.

*The controller calculates the Slow Rinse default time on injector type, system size and salt dosage. The cycle times can be adjusted for custom applications. Please contact your **YOUR SYSTEM NAME** Water Treatment Dealer before attempting to adjust the Slow Rinse time.

- **Operation Type**

This parameter displays the controller type and is preset at the factory: 268 softener, 263 filter.

- **Setting the Service Interval**

The service interval feature is an option that will allow the installer to program the unit to ask for maintenance after a programmed duration. The feature is programmed from 0 (zero) to 99 months. When the programmed length of time has been reached the words "CALL DEALER FOR SERVICE" will appear in the banner display to signal the end user that regular maintenance may be required. If it is set to 0 (zero) the function is disabled. If you wish to enable this function program the desired service interval duration.

- **Setting the Chlorine Generator/Salt Check (conditioner only)**

The controller has the capability to produce a low level of chlorine during the brine draw stage of regeneration. It can also sense if there is any brine present during the time when brine draw is occurring. This parameter can be adjusted to the following:

- 0 = Chlorine Generator with Salt Check disabled
- 1 = Chlorine Generator with Salt Check enabled
- 2 = Salt Check only

A chlorine generator refill control/cable kit must be installed for this function to work properly. After it is installed, select the desired parameter and push SET to accept the selection.

Level III Programming

Historical information can be retrieved from the controller by pressing the SET and DOWN buttons simultaneously, with the controller in the home position. Release both buttons when the controller displays MODEL NUMBER. Press the UP or DOWN buttons to navigate to each setting. The readout will scroll across the top of the display and the value will be displayed below the readout. Upon completing the initial programming procedure the average daily usages will display the same value. These values will change as the unit logs water usage.

Scrolling Display Readout	Range/Values	Valve Type	
		268	263
MODEL NUMBER^a		X	X
DAYS SINCE REGENERATION	0 to 255 days	X	X
PEAK FLOW RATE - DAY AND TIME	Language/Clock Mode Dependant	X	
PEAK FLOW RATE GPM^a	0 to 47 GPM	X	
WATER TREATED TODAY GAL	0 to 65536 gal.	X	
WATER SINCE REGENERATION GAL	0 to 65536 gal.	X	
SUNDAY AVERAGE USAGE GAL	0 to 65536 gal.	X	
MONDAY AVERAGE USAGE GAL	0 to 65536 gal.	X	
TUESDAY AVERAGE USAGE GAL	0 to 65536 gal.	X	
WEDNESDAY AVERAGE USAGE GAL	0 to 65536 gal.	X	
THURSDAY AVERAGE USAGE GAL	0 to 65536 gal.	X	
FRIDAY AVERAGE USAGE GAL	0 to 65536 gal.	X	
SATURDAY AVERAGE USAGE GAL	0 to 65536 gal.	X	
TOTAL WATER USED GAL X 100^a	0 TO 999900 gal.^a	X	
TOTAL WATER USED GAL X 1000000^a	0 to 42,940,000 gal.^a	X	
MONTHS SINCE SERVICE^a	0 to 2184 months^a	X	X

a. Bold text indicates that specific values can be reset. Press and hold the SET button for 5 seconds to reset the value.

Placing Conditioner Into Operation

Conditioner and Filter Start-Up

After you have performed the previous initial power-up steps, you will need to place the conditioner into operation. Follow these steps carefully, as they differ from previous valve instructions.



NOTE: The control valve can be started-up even if power is not yet available to the controller. The valve must be connected to the water supply. The motor can be unmounted from the valve, and the camshaft can be indexed manually counterclockwise by hand. This will allow the tank to be filled and allows regenerant draw to be tested.

Function	Display Text (268)	Display Text (263)
Treated Water	YOUR SYSTEM NAME (268)	YOUR SYSTEM NAME (263)
Regeneration	Backwash Brine Draw/Slow Rinse Pause - Please Wait Fast Rinse 1 Backwash 2 Fast Rinse 2 Brine Tank Refill	Backwash Pause - Please Wait Fast Rinse

1. Remove the cover from the valve. Removing the cover will allow you to see that the camshaft is turning, and in which cycle the camshaft is currently positioned.
2. With the supply water for the system still turned off, position the bypass valve to the "not in bypass" (normal operation) position.
3. Press and release the REGEN button on the controller. The scrolling text on the display will show "DELAYED REGENERATION". Press UP to navigate to "IMMEDIATE REGENERATION".
4. Press and release SET and UP to begin regeneration. The display will show eight LEDs moving from left to right on the banner display indicating that the motor is running. Additionally, the display will show the total regeneration time remaining.

Pressing SET when the motor has stopped displays the cycle description and cycle time remaining.

5. Press and release SET and UP simultaneously to advance to each cycle.
6. Advance the control to the Backwash. See below for the cycle sequences.
7. Fill the media tank with water.
 - A. While the controller is in cycle (Backwash), open the water supply valve very slowly to approximately the 1/4 open position.



WARNING: If opened too rapidly or too far, media may be lost out of the tank into the valve or the plumbing. In the ¼ open position, you should hear air slowly escaping from the valve drain line.

- B. When all of the air has been purged from the media tank (water begins to flow steadily from the drain line), open the main supply valve all of the way. This will purge the final air from the tank.
- C. Allow water to run to drain until the water runs clear from the drain line. This purges any refuse from the media bed.
- D. Turn off the water supply and let the system stand for about five minutes. This will allow any air trapped to escape from the tank.



NOTE: 263 Filter - advance control back to the treated water position, proceed to Step 12.

- 8. Add water to the regenerant tank (initial fill) (conditioner only).
 - A. With a bucket or hose, add approximately 4 gallons (15 liters) of water to the regenerant tank.

If the tank has a salt platform in the bottom of the tank, add water until the water level is approximately 1 inch (25 mm) above the platform.



NOTE: We recommend that you do not put regenerant into the tank until after the control valve has been put into operation. With no regenerant in the tank, it is much easier to view water flow and motion in the tank.

Action	Key	Duration	Display
Display current cycle	SET	5 Sec.	Current cycle
Advance to next cycle	SET and UP	Press and release	Next cycle
Cancel regeneration	SET and UP	5 Sec.	Regeneration canceled

9. Engage the refill cycle to prime the line between the regenerant tank and the valve (conditioner only).
 - A. Slowly open the main water supply valve again, to the fully open position. Be sure not to open too rapidly as that would push the media out of the media tank.
 - B. Advance the controller to the regenerant tank Refill position. From the Backwash 1 cycle, press and hold the SET button. This will display the current cycle.



NOTE: As you advance through each cycle there will be a slight delay before you can advance to the next cycle. There will be a pause after the brine draw and slow rinse cycles (system pause). This cycle allows the water/air pressure to equalize on each side of the valve discs before moving on.

- C. With the water supply completely open, when you arrive at the regenerant tank refill cycle, the controller will direct water down through the line to the regenerant tank. Let the water flow through the line until all air bubbles have been purged from the line.
 - D. Do not let the water flow down the line to the tank for more than one to two minutes, or the tank may overflow.
 - E. Once the air is purged from the line, press the SET button and the UP button simultaneously to advance to Treated Water position.
10. Draw water from the regenerant tank.
 - A. From the treated water position initiate a manual regeneration.

The controller will begin a manual regen, and advance the control valve to the backwash cycle. Press the SET and UP button to advance to brine draw/slow rinse cycle.
 - B. With the controller in this position, check to see that the water in the regenerant tank is being drawn out of the tank. The water level in the tank should recede very slowly.
 - C. Observe the water being drawn from the regenerant tank for at least three minutes. If the water level does not recede, or goes up, check all hose connections. C2 should be displayed.
11. If the water level is receding from the regenerant tank you can then advance the controller back to the treated water position by pressing SET and the UP buttons simultaneously.
12. Finally, turn on a faucet plumbed after the water conditioner. Run the faucet until the water runs clear.

Performa Exploded View

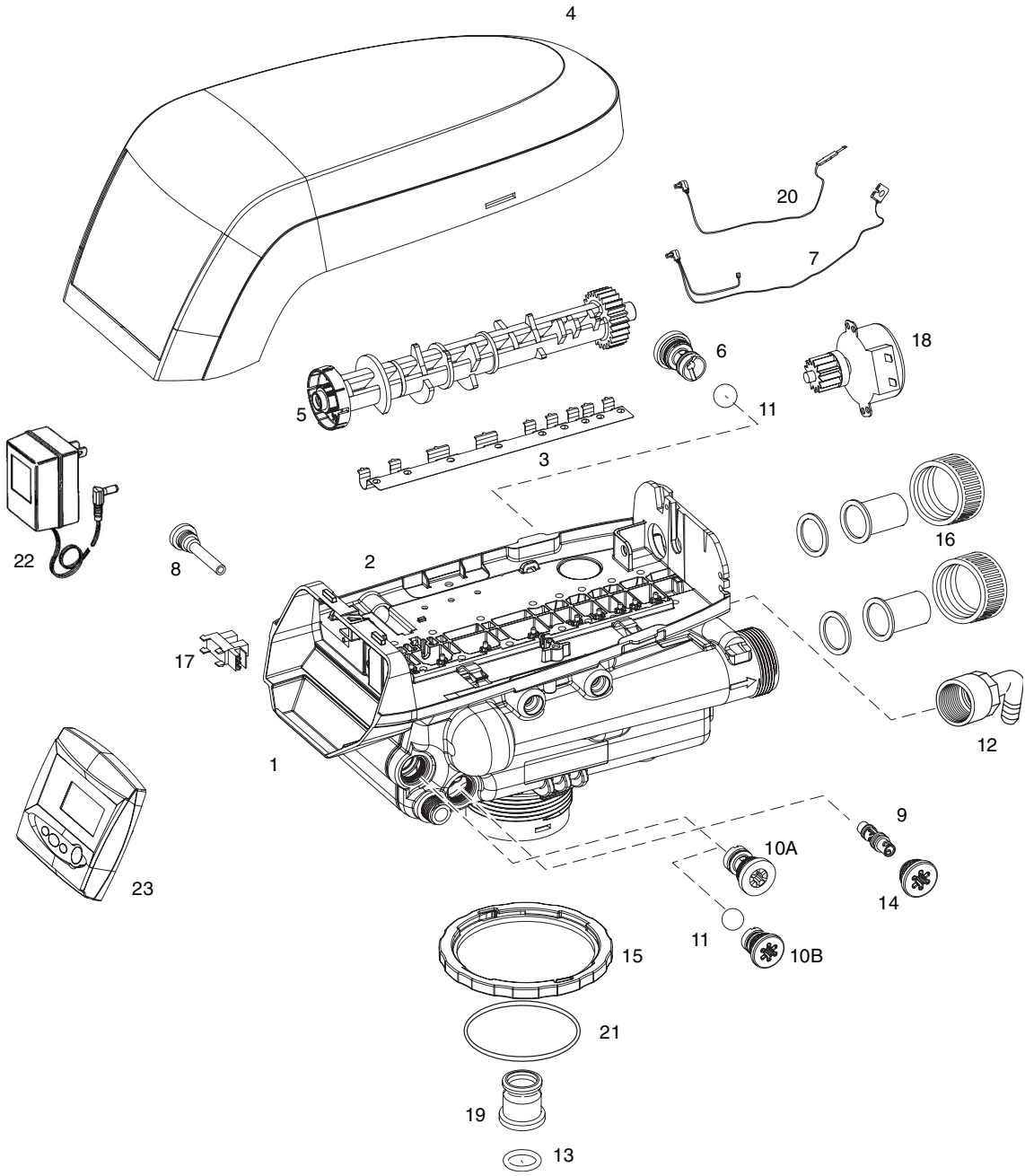

Warning: Do not use the flow control ball with #10A.

Performa Parts List

Code	Part No.	Description	Qty.	Code	Part No.	Description	Qty.
1	1244651	Valve Assembly w/o Flow Controls	1	16		Plumbing Adapter Kits:	1
2	1235338	Top Plate, Logix Series Valves	1	1001606	3/4-inch Copper Tube Adapter Kit		
3	1235339	Valve Disc Spring, One Piece, Performa Valve	1	1001670	1-inch Copper Tube Adapter Kit		
4	1236246	Cover, Valve, YOUR SYSTEM NAME Logix Series Controller	1	1001608	22-mm Copper Tube Adapter Kit		
5	1235352	Cam, 263-268 Logix Series Valve, STD, Black	1	1001613	3/4-inch CPVC Tube Adapter Kit		
6		Drain Control Assembly:	1	1001614	1-inch CPVC Tube Adapter Kit		
	1000212	No. 10 (2.5 gpm; 9.5 Lpm)		1001615	25-mm CPVC Tube Adapter Kit		
	1000213	No. 12 (3.5 gpm; 13.2 Lpm)		1001769	3/4-inch NPT Plastic Pipe Adapter Kit		
	1000214	No. 13 (4.1 gpm; 15.5 Lpm)		1001603	1-inch NPT Plastic Pipe Adapter Kit		
	1000215	No. 14 (4.8 gpm; 18.2 Lpm)		1001604	3/4-inch BSPT Plastic Pipe Adapter Kit		
7	1235269	Motor/Optical Cable Assembly, Logix Series Controller 12 V, 50/ Hz	1	1001605	1-inch BSPT Plastic Pipe Adapter Kit		
8	1000226	Screen/Cap Assembly w/ O-Ring	1	1001611	3/4-inch BSPT Brass Pipe Adapter Kit		
9		Injector (High Efficiency) Options:		1001610	1-inch NPT Brass Pipe Adapter Kit		
	1035733	"H" Injector (High Efficiency) - Lt Purple (9-inch tank)		1001612	1-inch BSPT Brass Pipe Adapter Kit		
	1035734	"J" Injector (High Efficiency) - Lt Blue (10-inch tank)		17	1235373	Module, Sensor, Photo Interrupter	1
	1030413	"K" Injector (High Efficiency) - Pink (12-inch tank)		18	1235361	Motor w/Spacer & Pinion, Logix Series Controller, 12 V, 50/60 Hz	
	1035736	"L" Injector (High Efficiency) - Orange (13 & 14-inch tank)		19	1001986	13/16 inch Rubber Insert (Optional)	1
	1032978	Plugged Injector for 263 Filter		20	1235446	Turbine Cable	1
	1032985	Plugged Injector Cap		21	1010154	Tank O-Ring	1
10A	1000222	Regenerant Refill Controller, No Ball	1	22	1000811	AC Adapter, North American	1
10B	1243510	Regenerant Refill Controller		23	XXXXXXX	Unprogrammed controller	1
11	1030502	Ball, Refill Flow Control		*	1033444	Turbine Assembly	
12	1002449	Drain Fitting Elbow (3/4-inch hose barbed)	1	*	1239979	Cable Harness, Remote Regen 740F	
13	1010428	O-Ring	1	*	1239711	Switch Kit, Front Mount, 0.1 amp	
14	1000269	Injector Cap with O-Ring	1	*	1239752	Switch Kit, Front Mount, 5 amp	
15	1035622	Tank Ring	1	*	1239753	Switch Kit, Top Plate Mount, 0.1 amp	
				*	1239754	Switch Kit, Top Plate Mount, 5 amp	
				*	1267808	Valve Skirt	
				*	1267811	Cover with Shield	
				*	1033444	Internal Turbine Meter	
				*	1233187	Motor Locking Pin	
				*	3002122	Chlorine Generator Kit	
				*	1239760	Blending Valve Kit Logix	
				*		Drain Line Flow Control	1
					1030355	Drain Line Flow Control, 5 gpm (19 Lpm)	
					1030356	Drain Line Flow Control, 6 gpm (22.5 Lpm)	
					1030357	Drain Line Flow Control, 7 gpm (26.5 Lpm)	
					1030358	Drain Line Flow Control, 8 gpm (30 Lpm)	
					1030359	Drain Line Flow Control, 9 gpm (34 Lpm)	
					1030360	Drain Line Flow Control, 10 gpm (38 Lpm)	
				*	1030334	Plugged Refill Flow Control - for 263 Valve	
				*	1041174	Valve Disc Kit	

*Not shown on drawing.

Troubleshooting

Logix Series Controller Troubleshooting

Problem	Possible Cause	Solution
ERR 1 is displayed.	Program settings have been corrupted.	Press any key and reset model number.
ERR 3 is displayed.	Controller does not know the position of the camshaft. Camshaft should be rotating to find Home position.	Wait for two minutes for the controller to return to Home position. The hourglass should be flashing on the display indicating the motor is running.
	Camshaft is not turning during ERR 3 display.	<p>Check that motor is connected. Verify that motor wire harness is connected to motor and controller module.</p> <p>Verify that optical sensor is connected and in place.</p> <p>Verify that motor gear has engaged cam gear.</p> <p>If everything is connected, try replacing in this order:</p> <ul style="list-style-type: none"> —Wire harness —Motor —Optical sensor —Controller
	If camshaft is turning for more than five minutes to find Home position:	<p>Verify that optical sensor is in place and connected to wire.</p> <p>Verify that camshaft is connected appropriately.</p> <p>Verify that no dirt or rubbish is clogging any of the cam slots.</p> <p>If motor continues to rotate indefinitely, replace the following components in this order:</p> <ul style="list-style-type: none"> —Wire harness —Motor —Optical sensor —Controller
Time of Day incorrect.	Power failure occurred.	Press SET to reset the time display.

System Troubleshooting

Problem	Possible Cause	Solution
1. Brine tank overflow.	<ul style="list-style-type: none"> a. Uncontrolled brine refill flow rate. b. Air leak in brine line to air check. c. Drain control clogged with resin or other debris. 	<ul style="list-style-type: none"> a. Remove brine control to clean ball and seat. b. Check all connections in brine line for leaks. Refer to instructions. c. Clean drain control.
2. Flowing or dripping water at drain or brine line after regeneration.	<ul style="list-style-type: none"> a. Valve stem return spring weak. b. Debris is preventing valve disc from closing. 	<ul style="list-style-type: none"> a. Replace spring. (Contact dealer.) b. Remove debris.
3. Hard water leakage after regeneration.	<ul style="list-style-type: none"> a. Improper regeneration. b. Leaking of external bypass valve. c. O-ring around riser pipe damaged. d. Incorrect capacity. 	<ul style="list-style-type: none"> a. Repeat regeneration after making certain correct regenerant dosage was set. b. Replace bypass valve. (Contact dealer.) c. Replace O-ring. (Contact dealer.) d. Verify appropriate regenerant amount and system capacity. (Contact dealer.)
4. Control will not draw brine.	<ul style="list-style-type: none"> a. Low water pressure. b. Restricted drain line. c. Injector plugged. d. Injector defective. e. Valve disc 2 and/or 3 not closed. f. Air check valve prematurely closed. 	<ul style="list-style-type: none"> a. Make correct setting according to instructions. b. Remove restriction. c. Clean injector and screen. d. Replace injector and cap. (Contact dealer.) e. Remove foreign matter from disc and check disc for closing by pushing in on stem. Replace if needed. (Contact dealer.) f. Put control momentarily into brine refill. Replace or repair air check if needed. (Contact dealer.)
5. Control will not regenerate automatically.	<ul style="list-style-type: none"> a. AC adapter or motor not connected. b. Defective motor. 	<ul style="list-style-type: none"> a. Connect power. b. Replace motor. (Contact dealer.)
6. Control regenerates at wrong time of day.	<ul style="list-style-type: none"> a. Controller set incorrectly. 	<ul style="list-style-type: none"> a. Correct time setting according to instructions.
7. Valve will not draw brine.	<ul style="list-style-type: none"> a. Low water pressure. b. Restricted drain line. c. Injector plugged. d. Injector defective. e. Air check valve closes prematurely on brine pickup tube. 	<ul style="list-style-type: none"> a. Set pump to maintain 20 psi at softener. b. Change drain to remove restriction. c. Clean injector and screen. d. Replace injector. (Contact dealer.) e. Put control momentarily into brine/slow rinse. Replace or repair air check if needed. (Contact dealer.)
8. System using more or less salt than regenerant setting.	<ul style="list-style-type: none"> a. Foreign matter in valve causing incorrect flow rates. 	<ul style="list-style-type: none"> a. Remove brine control and flush out foreign matter. Advance control to brine/slow rinse, to clean valve (after so doing position control to "fast rinse" to remove regenerant from tank).
9. Intermittent or irregular regenerant draw.	<ul style="list-style-type: none"> a. Low water pressure. b. Defective injector. 	<ul style="list-style-type: none"> a. Set pump to maintain 20 psi at conditioner. b. Replace injector. (Contact dealer.)
10. No conditioned water after regeneration.	<ul style="list-style-type: none"> a. No regenerant in regenerant tank. b. Injector plugged. c. Air check valve closes prematurely. 	<ul style="list-style-type: none"> a. Add regenerant to regenerant tank. b. Clean injector and screen. c. Put control momentarily into brine/slow rinse. Replace or repair air check if needed. (Contact dealer.)

Problem	Possible Cause	Solution
11. Backwashes or purges at excessively low or high rate.	<ul style="list-style-type: none"> a. Incorrect drain controller used. b. Foreign matter affecting valve operation. 	<ul style="list-style-type: none"> a. Replace with correct size controller. (Contact dealer.) b. Remove drain controller and clean ball and seat.
12. No water flow display when water is flowing.	<ul style="list-style-type: none"> a. Bypass valve in bypass. b. Meter probe disconnected or not fully connected to meter housing. c. Restricted meter turbine rotation due to foreign material in meter. 	<ul style="list-style-type: none"> a. Shift bypass valve to not-in-bypass position. b. Fully insert probe into meter housing. c. Remove meter housing, free up turbine and flush with clean water. Turbine should spin freely. If not, replace meter. (Contact dealer.)
13. Run out of conditioned water between regenerations.	<ul style="list-style-type: none"> a. Improper regeneration. b. Incorrect regenerant setting. c. Incorrect hardness or capacity settings. d. Water hardness has increased. e. Restricted meter turbine rotation due to foreign material in meter. 	<ul style="list-style-type: none"> a. Repeat regeneration, making certain that correct regenerant dosage is used. b. Set P6 to proper level. See salt setting chart. c. Set to correct values. See Programming section. d. Set hardness to new value. See Programming section. e. Remove meter housing, free up turbine and flush with clean water. Turbine should spin freely; if not, replace meter. (Contact dealer.)
14. Regenerant tank overflow.	<ul style="list-style-type: none"> a. Regenerant valve disc 1 being held open by foreign matter. b. Valve disc 2 not closed during regenerant draw causing brine refill. c. Air leak in regenerant line to air check. d. Improper drain control for injector. e. Drain control clogged with resin or other debris. 	<ul style="list-style-type: none"> a. Manually operate valve stem to flush away obstruction. b. Flush out foreign matter holding disc open by manually operating valve stem. c. Check all connections in regenerant line for leaks. Refer to instructions. d. Too small of a drain control with a larger injector will reduce draw rates. e. Clean drain control.

